



FRÍANT

Shield Screens and Panels

Products that address the return to the office.

TABLE OF CONTENTS

INTRODUCTION

Terms and Conditions	3
Care and Maintenance	6
Standard Fabrics	7
Pattern Direction	8
Standard Finishes	9

APPLICATION GUIDE

Verity	12
My-Hite	14
Interra	15
System 2	15
Novo	16

SHIELD PRODUCTS

Freestanding Laminate Panel Feet	18
Freestanding Laminate Panel Casters	19
Freestanding Markerboard Panel Feet	20
Freestanding Markerboard Panel Casters	21
Shield Acrylic Freestanding Screen	22
Shield Acrylic Clamp Screen	24
Shield Acrylic Panel-Mounted Screen	25

MY-HITE/UNIVERSAL

PRIVACY SCREENS

Worksurface mounted	
Acrylic screen (NEW)	27
Worksurface mounted	
Fabric covered screens (NEW)	29
Worksurface mounted glass screens	30
Privacy Screen, Fabric	32
Privacy Screen, Marker Board	33
Privacy Screen, Laminate	34

VERITY

SUPPORTING STORAGE

Cabinets	36
----------	----

STORAGE

Over-Worksurface Storage	
Single-Sided	37
Double-Sided	40

TRACK-MOUNTED ACCESSORIES

Fabric Screen	41
Glass Screen	42
Acrylic Screen (NEW)	43

WORKSURFACE-MOUNTED ACCESSORIES

Acrylic Screen (NEW)	44
Fabric Tackboard	45
Glass Screen	46
Markerboard Screen	47

INTERRA

FRAMES

Stacking Frames	48
-----------------	----

TILES

Perforated Metal Tile	49
Laminate Tile (NEW)	50

SCREENS

Frameless Glass	51
Top Cap with Glass	53
Panel Mounted Acrylic Screen (NEW)	55

SYSTEM 2

SCREENS

Frameless Glass	57
Panel Mounted Acrylic Screen (NEW)	58

NOVO

SCREENS

Frameless Glass	60
Panel Mounted Acrylic Screen (NEW)	62

Terms and Conditions

PRICES

Pricing is delivered, freight included to 48 contiguous states. Specific requirements apply, minimum order required, see freight policy for details. See complete freight rules and policy on www.friant.com.

ORDERING

Purchase Orders should be sent to orders@friant.com or faxed to (510) 535-6895. If your specifications were created with CAP, GIZA or Project Matrix, please send the worksheet (.SP4, or .SIF) with your Purchase Order.

TERMS

Net 30 days from date of invoice. Invoices are delinquent if not paid 30 days from date of invoice. In the event timely payment is not made, interest will be charged at the rate of 1.5% per month on delinquent accounts. Buyers will also be liable for normal collection costs and attorney's fee. 50% deposit is required with every order, unless prior arrangements have been made.

ORDERS

Orders are only accepted by issuance of our formal acknowledgment, and are subject to the terms set forth herein and on our order acknowledgment. It is the responsibility of the buyer to review our acknowledgment for accuracy.

LEAD TIME

Lead times are subject to availability, see www.Friant.com for details.

SHIPPING

Friant generally palletizes, boxes and/or shrink-wraps its products. If buyer requests additional packaging or special shipping, then it is responsible for any extra costs that result. Buyer obtains title to products and assumes the risk of loss for them upon shipment from Friant's plant.

CLAIMS

We are not responsible for damage suffered in transit. Merchandise should be inspected for possible freight damage upon delivery. The consignee should file for damage or shortages with the carrier within 5 days of delivery. You are also protected for "concealed damage" if you file claim with the carrier within 5 days of delivery. Buyer must make all claims against Friant for defects, errors or shortages in writing within 10 days after delivery. Failure to make such a claim shall constitute full acceptance.

RETURNS

No merchandise may be returned without our written consent and shipping instructions. Unauthorized returns will not be accepted and will be returned freight collect.

PARTIAL SHIPMENTS

We will make every attempt to ship orders complete and on schedule. However, we reserve the right to make partial shipments, as merchandise is ready. Invoices covering these shipments are to be paid as they become due.

ORDER CHANGE/CANCELLATIONS

Our order confirmation is final and binding. Product is made to order, no returns or cancellations are permitted. For the most up to date information, always review the order change/cancellation policy online.

SHIPMENT AND PREPAID FREIGHT

Unless otherwise instructed, we reserve the option to ship by what is, in our opinion, the best possible way. Upon request, we will prepay and add freight for accounts with established credit.

DELIVERY

We are not liable for delay or failure of delivery due to strikes and/or differences with workmen, war, riot, fire, compliance with government regulations, acts of nature, failure or delays of sources of supply, or any other causes beyond our control.

STORAGE

If buyer cannot accept delivery when merchandise is ready, we reserve the right to transfer goods to storage. Costs of transfer and storage will be charged to the buyer's account, and we will deem such transfer as constituting shipment for all purposes, including invoicing, as of the date the transfer is made.

Terms and Conditions

CONSTRUCTION — SPECIFICATIONS

All items are produced to price list specifications unless otherwise advised. All dimensions shown are approximate. Manufacturer reserves the right to make modifications and/or improvements without prior notice.

FABRIC APPLICATION

Standard fabric application is non-directional. Friant & Associates is not responsible for charges associated with replacement of products due to incorrect specifications. Certain product construction and sizes require fabric to be applied only Directionally or Non-Directionally. See individual pricebook specifications for details.

CUSTOMER'S OWN MATERIAL

Yardage requirement is based on 66" wide plain covering material, and must be increased if less than 66" wide. Special instructions for handling material (pattern, directional fabric, right side of reversible fabric, etc.) must be submitted in writing before fabric is delivered. In the absence of special instructions, we reserve the right to use our own judgment. We reserve the right to reject any covering, which in our opinion, is unsuitable for our upholstery purposes. However, in no instance shall we be held responsible for unsatisfactory results due to use of covering unsuitable for our upholstery methods.

We will not be responsible for errors caused by buyers not supplying us with sample cuttings attached to their order giving full identification of covering material, (name of supplier, covering name, number and color) for identification purposes and advising us of model number and quantity to which each cover is to be applied.

Customer's own material that is shipped freight collect will be refused. A service charge will be applied for the return of unusable C.O.M. Contact factory.

RIGHTS AND WARRANTIES — LIMITED LIFETIME

This warranty is given to the initial purchaser and is valid from the date of purchase, for as long as the initial purchaser owns the product. This warranty covers defects in material and craftsmanship found during normal usage of the product during the warranty period. Normal usage is defined by 8 hour shifts in the product's intended application and in an indoor environment that conforms to the ANSI/ASHRAE Standard 55: Thermal Environmental Conditions for Human Occupancy (relating to air temperature, mean radiant temperature, air velocity, clothing insulation, metabolic rate, and humidity). Friant's warranty does not cover usage other than normal usage as defined in the previous sentence. If the product is defective, and if written notice of the defect is given to Friant & Associates within the applicable warranty period, Friant & Associates, at its option, will either repair or replace the defective product with a comparable component or product. This warranty applies to all products except as noted below.

High wear parts, such as wood veneer, fabrics, laminates, acrylic, and other covering material/finishes, foam, glides, etc. are warranted for one (1) year. This warranty does not apply to damage caused by a carrier, alteration to the product not expressly authorized by Friant & Associates, nor to product considered to be of a consumable nature such as bulbs, light ballasts, etc. It also does not apply to "Customer's Own Material" (i.e. material specified by the customer that is not a standard Friant & Associates offering) used in the manufacture of Friant & Associates products.

Many Shield products are offered with flexible mounting options that can be utilized in many different applications and paired with many different furniture solutions. It is the sole responsibility of the ordering dealer to identify the proper application, order appropriate hardware and ensure all Shield products are securely and safely installed. Shield products have not been certified by a 3rd party laboratory to meet or exceed ANSI/BIFMA standards.

Product is made to order, no returns or cancellations.

Our warranty for LED lights is 2 years.

Friant & Associates does not warrant the matching of colors, grain or texture, except to within commercially acceptable standards. This includes normal variations between dye lots (fabrics).

A product will not be considered defective, and Friant & Associates will not be obligated to replace it, if it is not installed in a proper manner (i.e. product not leveled, not secured properly, etc.) or if it is not used in a manner and/or in an environment that constitutes normal usage, as defined above.

Except as noted above, Friant & Associates makes no express or implied warranties to any product, and in particular makes no warranty of fitness for any particular use. At Friant & Associates' option, product repair and replacement is the customer's exclusive remedy for any and all product defects.

Friant & Associates shall not be liable for consequential, economic, or incidental damages arising from any product defect.

Terms and Conditions

CALIFORNIA PROP 65 WARNING

Products in this catalog can expose you to chemicals including wood dust, which is known to the State of California to cause cancer or birth defects or other reproductive harm. For more information go to <https://www.p65warnings.ca.gov/products/furniture-products>.”

CARB

Friant products are CARB 93120 compliant for formaldehyde (phase 2)

TSCA TITLE VI

Friant products are TSCA Title VI Compliant

MAS

Accredited Compliance Designation - ANSI/BIFMA x7.1 & e3-2014 7.6.1, 7.6.2, 7.6.3

California Dept. Of Public Health Standard Method v1.2

Conforms With: LEED v4

Criteria of MAS Certified Green ® Program

Finish Care & Maintenance Guide

With regular care and maintenance, your Friant furniture will provide years of superior performance and satisfaction. To maintain the finish quality of your Friant products, please follow the cleaning procedures provided below. The instruction for the care and maintenance of Friant products are provided to you as a service. No warranty is implied, since we cannot monitor the methods and materials used for maintenance.

COATED METAL

For normal cleaning, wipe coated metal surfaces with a soft cloth, soaked in detergent and warm water; rinse thoroughly and dry. Remove scuff marks from low-gloss coatings with pre-softened paste wax, following the manufacturer's instructions.

Remove scuff marks and scratches from high-gloss coatings using automotive polishing compounds, either liquid or paste. After polishing, apply a pre-softened automotive paste wax to restore original sheen.

POLISHED ALUMINUM

For normal cleaning, apply a pre-softened paste wax to polished aluminum components following the manufacturer's instructions. In humid atmospheres near salt water, apply the wax once a month. In other areas, apply wax every three months to maintain the appearance of the aluminum.

POLISHED CHROME

For normal cleaning, wet cheesecloth in a nonabrasive cleaner, like liquid dish soap, and rub the chrome component lightly until the original luster reappears. Dry the component with a soft cloth to remove any soap residue.

SEATING/ PANEL FABRICS

The following are general recommendations to maintain the good condition of your panel fabric:

- Vacuum the fabric periodically to remove accumulated dirt and dust. The required frequency of this and any other routine maintenance is determined by end use conditions.
- Blot fresh spills immediately.
- Ensure that the fabric is adequately rinsed after cleaning, as residual cleaning agents may accelerate soiling.
- Have the fabric professionally cleaned whenever large stains or an overall soiled conditions occurs.

For most water-based stains, a clean, absorbent cloth dampened with a detergent solution (e.g. 1 teaspoon laundry detergent/1 pint warm water) should be applied to the stain. Blot the fabric with the treated cloth, working from the outer edge of the stained area, moving inward. In order to effectively draw out the stain, renew the cleaning cloth frequently. Rinse well with clear water, and dry the fabric as quickly as practical. Oil-based stains may be treated in manufacturer's recommendations for using such products, and always pretest an inconspicuous area of the fabric for colorfastness to the cleaning agent.

For stains that do not respond to these basic methods, please contact a professional upholstery cleaner.

LAMINATES

For normal cleaning, wipe the laminate with a soft cloth and a solution of mild detergent and warm water. Rinse thoroughly and dry with a soft cloth.

For minor repair of stubborn marks, apply a nonabrasive liquid kitchen cleanser with a soft cloth soaked in warm water. Rub in the direction of the grain; use caution to avoid damaging the surface texture or gloss. If no grain direction is visible, rub with a light, circular motion.

You can use acetone, alcohol, Windex, or a typical non-abrasive house hold cleaner including a bleach water solution. Do not use powdered abrasives or other harsh cleansers like hypochlorite bleach, hydrogen peroxide, nitric or hydrochloric acids or lye; they may deface the surface and change the finish color.

WOOD & VENEER

For normal cleaning, dust furniture daily with a slightly damp, soft, lint-free cloth. Wipe dry with a dry, soft cloth in the direction of the wood grain.

Once a month, clean the surface with a soft cloth dampened with a quality cleaner formulated for wood furniture. Wipe the surface in the direction of the wood grain to remove dirt and fingerprints. Wipe dry with a clean, dry cloth.

Twice a year, apply a good quality emulsion wax with a soft cloth. Emulsion wax is clear and prevents fingerprints. Do not use aerosol-powered cleaners, polishes, waxes, abrasive cleaners, or oily polishes.

For minor repair of water rings, stains and scratches, rub the surface lightly in the direction of the wood grain using No. 000 steel wool. Apply a scratch-removing polish with a color and value that simulate the veneer. If the scratches are deep, consult a professional furniture refinisher.

GLASS

Use cleaning products specifically designed for glass.

ACRYLIC

Start by looking at how dirty the surface is. This will help you determine how strong of a cleaning solution you need to use. In some cases you might want to use a spray bottle or soak the surfaces if possible. For daily cleaning wipe acrylic surfaces with a soft cloth soaked in mild dish soap and warm water. Rinse thoroughly and dry with a soft cloth. Do not use solvents or abrasive kitchen cleaners.

CHAIR BASES

For normal cleaning, wipe bases with warm, soapy water. Rinse and wipe dry with a soft cloth. Do not use any solvents or abrasive materials.

Standard Fabrics

JOURNEY		SLIDE		SILKY		SKY	
PF801-1	Quest	PF101-1	Caramel	PF401-1	Natural	PF301-1	Terra
PF801-2	Voyage	PF101-2	Slate	PF401-2	Parids	PF301-2	Birch
PF801-3	Transit	PF101-3	Pewter	PF401-3	Overcast	PF301-3	Moss
PF801-4	Amble	PF101-7	Java	PF401-5	Graphite		
PF801-5	Odyssey	PF101-9	Sterling				
PF801-6	Caravan	PF101-10	Crema				
PF801-7	Expedition	PF101-13	Mustard				
PF801-8	Wayfare	PF101-14	Avocado				
		PF101-15	Pumpkin				
		PF101-16	Ocean				
		PF101-17	Blueberry				
		PF101-18	Cardinal				
		PF101-19	Flamingo				
		PF101-20	Serenity				
		PF101-21	Azure				
		PF101-22	Orchid				
		PF101-23	Plum				
		PF101-24	Raven				

LIMITED AVAILABILITY

SLIDE		SILKY		STICKS	
PF101-4	Verde	PF401-4	Field	PF501-3	Sage
PF101-6	Vintage			PF501-4	Straw
PF101-8	Latte				
PF101-12	Stem				

Fabric is scheduled for discontinuation when inventory is exhausted. Please contact Customer Service for current stock levels. After discontinuation fabric will be available with extended lead time, subject to minimum yardage requirements.

NOTES:

- Passage and Terrain are not available on acoustical panels, pedestal cushions, tackboards or fabric screens.
- Please refer to the Fabric Direction Section in the Materials Reference Guide on the Dealer Resource Center for more details: <http://dealers.friant.com/dealers/product-literature/>
- Order fabric / finish sample online at www.friant.com
- Colors may vary slightly between dye lots.

Pattern Direction

- Fabric direction is not always determined by the way the pattern is shown on memo sample.
- Certain product construction and sizes require fabric to be applied only Directionally or Non-Directionally.
- Some products have fabric applied either Directionally or Non-Directionally. (Upcharges may apply on some products, see price books for details).
- Please refer to our Materials Reference Guide on the Dealer Resource Center for specific pattern application defaults on all of our products : <http://dealers.friant.com/dealers/product-literature/>
- Our Customer Service Team is happy to answer any questions regarding fabric direction.

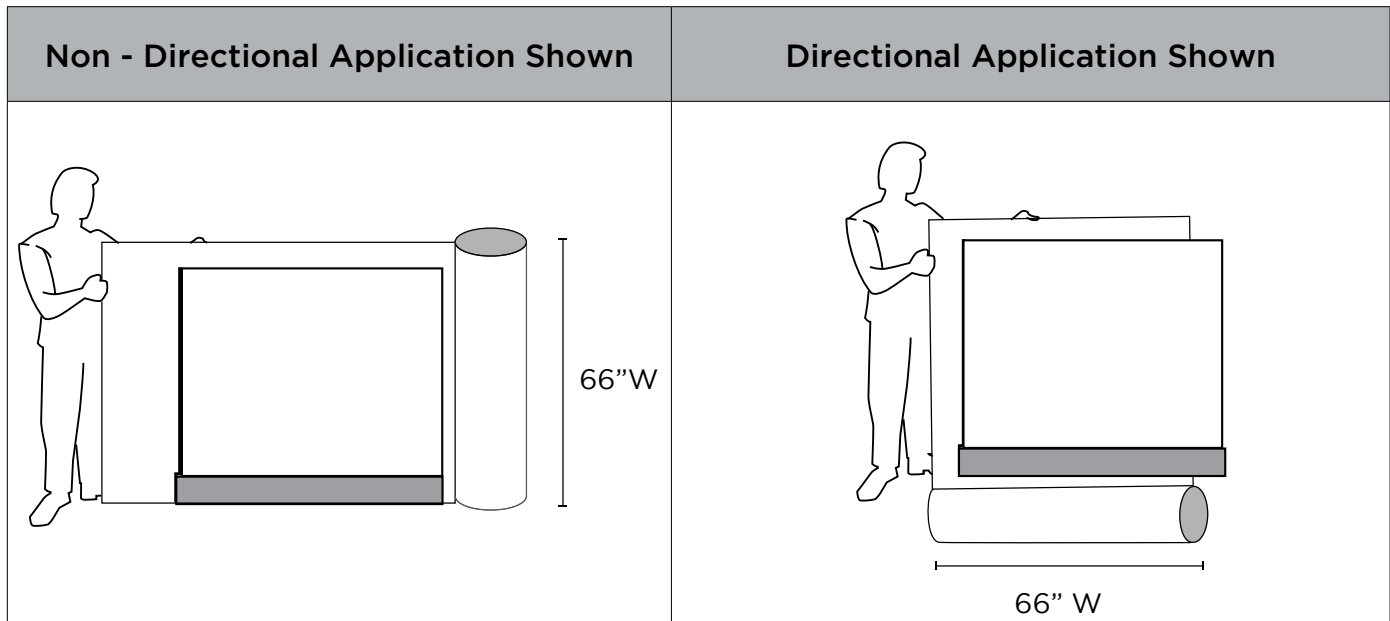

Standard Finishes

Use the matrix below to identify surface and hardpanel finish options. Please note, M1-M13 offer close matching finishes, while M14-M29 are paired as color matched finishes.

Specify hardsurface panel finish for Interra laminate tiles

Specify surface finish on Shield panels and laminate privacy screens. For Shield panels, colors available are marked below

* Shield Standard lead time

** Shield Quickship

All other colors available on Shield panels through Customs

Order samples at
www.friant.com/samples

Please Note: Images are printed simulations and are not exact matches of finished product. Please request an actual sample from Friant or your sales consultant before specifying finishes.

PAINT TRIM

CW Cloud White

BU Black Umber

SV Silver

SURFACE FINISHES		HARDSURFACE PANEL FINISHES		SUPPLIER
M1	Light Maple*	7909-60	Fusion Maple	Wilsonart
M2	Light Cherry	7054-60	Wild Cherry	Wilsonart
M3	Medium Cherry	7924K-70	Biltmore Cherry	Wilsonart
M4	Dark Mahogany	7040K-78	Figured Mahogany	Wilsonart
M5	Light Mahogany	7039K-78	Windsor Mahogany	Wilsonart
M6	Light Gray	D327-60	Pepperdust	Wilsonart
M7	Off White	1572-60	Antique White	Wilsonart
M8	Gray Specks	4621-60	White Nebula	Wilsonart
M9	Cloud White**	1573-60	Frosty White	Wilsonart
M10	Espresso*	7933K-07	Cafelle	Wilsonart
M11	Light Walnut*	7937-60	River Cherry	Wilsonart
M12	Medium Walnut	7965K-12	Walnut Heights	Wilsonart
M13	Licorice	FB3920	Licorice Groovz	Arauco
M14	Carob	FB3560	Driftwood	Arauco
M15	Mousse	FB2960	Mochatini	Arauco
M16	Tundra	FB3930	Concrete Groovz	Arauco
M17	Cocoa	FB2990	Nirvana	Arauco
M18	Capitan	FB3400	Aria	Arauco
M19	Fog	FB2100	Silver Frost	Arauco
M20	Sandstone	FB2090	Shadow Frost	Arauco
M21	Medium Oak	FB2030	Seria	Arauco
M22	Harbor	FB4310	Umbr	Arauco
M23	Bark	FB3970	Stromboli	Arauco
M24	Tarmac	FB4320	Ashen	Arauco
M25	Winter	FB2130	Fog Grey	Arauco
M26	Storm	FB2000	Pewter Frost	Arauco
M27	Medium Ash	8842	Weathered Ash	Formica
M28	Arctic	8841	White Ash	Formica
M29	Raven	1595-60	Black	Wilsonart
		D91-60	Slate Gray	Wilsonart

Contact suppliers directly for hardsurface panel finish samples.

Wilsonart

tel: 800-433-3222, <https://www.wilsonart.com/contact-us>

Formica

tel: 800-367-6422, <https://www.formica.com/en-us/collections/commercial-ranges>

Arauco

Samples can be ordered at <https://store.samplingproduct.com/8340>.

Special Materials

Antimicrobial Laminates

Wilsonart HD laminates with built in antimicrobial protection

Available in 45 colors

<https://www.wilsonart.com/laminate/wilsonart-hd>

Available as a special material application. Submit Custom quote request through the Dealer Resource Center.

Bleach Cleanable Fabrics

Guilford of Maine offers bleach-cleanable fabrics

<https://www.guilfordofmaine.com/>

Some have already been approved for COM application

Bailey

Beacon

Hatchet

Pursuit

Synopsis

These are available through the standard COM process. Please contact Customer Service for any questions about COM.

Antimicrobial Finish

Guilford of Maine offers an antimicrobial finish that can be added to any of their patterns

<https://www.guilfordofmaine.com/>

A complete list of Guilford of Maine fabrics that have been approved for COM can be found in the Dealer Resource Center.



SIMPLE DESIGNS | FAST TO INSTALL | EASY TO CLEAN

SHIELD by Fríant

We have designed our new Shield Screens and Panels to provide solutions relevant for addressing “back to the office” solutions that help define space between employees and keep them feeling as comfortable as possible.

VERITY

- 1** Track Mounted Screens 44
- 2** Worksurface Mounted Screens 47
- 3** Freestanding Shield Panel 18



- 1** Track Mounted Screens 44
- 2** Worksurface Mounted Screens 47
- 3** Supporting Storage 39



- 1** Over worksurface Storage 40
- 2** Track Mounted Screens 44
- 3** Worksurface Mounted Screens 47



VERITY

- 1** Track Mounted Screens 41
- 2** Shield Freestanding Screens 22



- 1** Worksurface Mounted Screens 44
- 2** Track Mounted Screens 41
- 3** Shield Mobile Panel 19



MY-HITE

1 Shield Freestanding Screens 22



MY-HITE & BEAM

1 Shield Clamp Screens 24



INTERRA

- 1 Freestanding Shield Panels 18



SYSTEM 2

- 1 Privacy Screens 32
- 2 Shield Panel-Mounted Screen 25



NOVO

1 Shield Freestanding Panel 18



1 Shield Freestanding Screen 22





SHIELD Freestanding Laminate Panel Feet

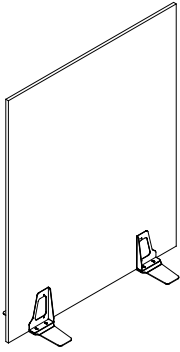

DESCRIPTION

Freestanding laminate panel with feet.

NOTES

- Dimensions are actual
- Laminate is 3/4" thick
- Laminate colors:
 - M1 Light Maple
 - M9 Cloud White*
 - M10 Espresso
 - M11 Light Walnut
 - For all other laminate colors, please request a Custom quote
 - *Quickship
- Painted metal feet in Cloud White

SPECIFICATION OPTIONS

product #: see charts below
surface finish: see notes below

ORDER EXAMPLE

product #: FZFS.4853
surface finish: M9 Cloud White

45" HIGH

PART #	HEIGHT	WIDTH	LIST
FZFS.3045	45"	30"	\$858
FZFS.3645	45"	36"	\$916
FZFS.4245	45"	42"	\$974
FZFS.4845	45"	48"	\$1,031

53" HIGH

PART #	HEIGHT	WIDTH	LIST
FZFS.3053	53"	30"	\$910
FZFS.3653	53"	36"	\$978
FZFS.4253	53"	42"	\$1,045
FZFS.4853	53"	48"	\$1,113

60" HIGH

PART #	HEIGHT	WIDTH	LIST
FZFS.3060	60"	30"	\$956
FZFS.3660	60"	36"	\$1,070
FZFS.4260	60"	42"	\$1,146
FZFS.4860	60"	48"	\$1,222

SHIELD Freestanding Laminate Panel Casters

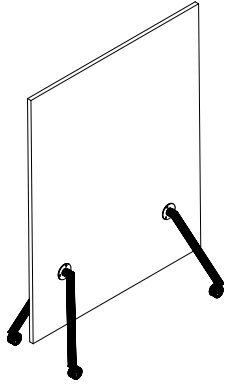

DESCRIPTION

Freestanding laminate panel with casters.

NOTES

- Dimensions are actual
- Laminate is 3/4" thick
- Laminate colors:
 - M1 Light Maple
 - M9 Cloud White*
 - M10 Espresso
 - M11 Light Walnut
 - For all other laminate colors, please request a Custom quote
 - *Quickship
- Legs are cloud white, casters are white
- Includes 4 locking casters

SPECIFICATION OPTIONS

product #: see charts below
surface finish: see notes below

ORDER EXAMPLE

product #: FZF5MOB.4845
surface finish: M9 Cloud White

45" HIGH

PART #	HEIGHT	WIDTH	LIST
FZF5MOB.4245	45"	42"	\$1,103
FZF5MOB.4845	45"	48"	\$1,161

53" HIGH

PART #	HEIGHT	WIDTH	LIST
FZF5MOB.4253	53"	42"	\$1,175
FZF5MOB.4853	53"	48"	\$1,242

60" HIGH

PART #	HEIGHT	WIDTH	LIST
FZF5MOB.4260	60"	42"	\$1,238
FZF5MOB.4860	60"	48"	\$1,314

SHIELD Freestanding Markerboard Panel Feet

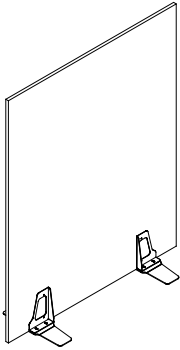

DESCRIPTION

Freestanding markerboard panel with feet.

NOTES

- Dimensions are actual
- Markerboard is 3/4" thick
- Painted metal feet in Cloud White

SPECIFICATION OPTIONS

product #: see charts below

ORDER EXAMPLE

product #: FZFMBS.4853

45" HIGH

PART #	HEIGHT	WIDTH	LIST
FZFMBS.3045	45"	30"	\$1,354
FZFMBS.3645	45"	36"	\$1,510
FZFMBS.4245	45"	42"	\$1,667
FZFMBS.4845	45"	48"	\$1,823

53" HIGH

PART #	HEIGHT	WIDTH	LIST
FZFMBS.3053	53"	30"	\$1,494
FZFMBS.3653	53"	36"	\$1,678
FZFMBS.4253	53"	42"	\$1,862
FZFMBS.4853	53"	48"	\$2,046

60" HIGH

PART #	HEIGHT	WIDTH	LIST
FZFMBS.3060	60"	30"	\$1,616
FZFMBS.3660	60"	36"	\$1,862
FZFMBS.4260	60"	42"	\$2,071
FZFMBS.4860	60"	48"	\$2,279

SHIELD Freestanding Markerboard Panel Casters

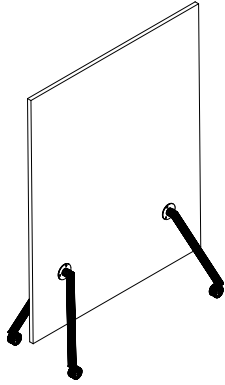

DESCRIPTION

Freestanding markerboard panel with casters.

NOTES

- Dimensions are actual
- Markerboard is 3/4" thick
- Legs are cloud white, casters are white
- Includes 4 locking casters

SPECIFICATION OPTIONS

product #: see charts below

ORDER EXAMPLE

product #: FZFMBSMOB.4845

45" HIGH

PART #	HEIGHT	WIDTH	LIST
FZFMBSMOB.4245	45"	42"	\$1,796
FZFMBSMOB.4845	45"	48"	\$1,953

53" HIGH

PART #	HEIGHT	WIDTH	LIST
FZFMBSMOB.4253	53"	42"	\$1,991
FZFMBSMOB.4853	53"	48"	\$2,176

60" HIGH

PART #	HEIGHT	WIDTH	LIST
FZFMBSMOB.4260	60"	42"	\$2,162
FZFMBSMOB.4860	60"	48"	\$2,370

Shield Acrylic Screen, Freestanding, 1 7/8" Base

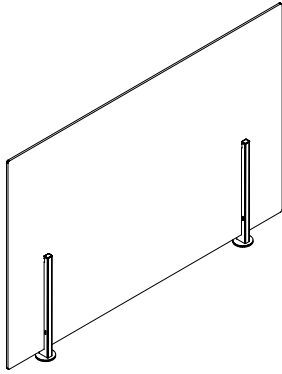

DESCRIPTION

Shield clear acrylic screen with freestanding hardware attachment, 1 7/8" base.

NOTES

- Freestanding hardware attaches with removable adhesive
- Round hardware base diameter is 1 7/8"
- Hardware is silver
- Clear acrylic screen, 5mm thick
- Actual screen size is less 1/2" high and 1/8" wide
- Sold individually

SPECIFICATION OPTIONS

product #: see charts below

ORDER EXAMPLE

product #: FPSF2.1448-CL

FREESTANDING SCREEN 14" HIGH CLEAR, 1 7/8" BASE

PART #	HEIGHT	WIDTH	LIST
FPSF2.1424-CL	14"	24"	\$394
FPSF2.1430-CL	14"	30"	\$409
FPSF2.1436-CL	14"	36"	\$423
FPSF2.1442-CL	14"	42"	\$438
FPSF2.1448-CL	14"	48"	\$453
FPSF2.1454-CL	14"	54"	\$468
FPSF2.1460-CL	14"	60"	\$482

FREESTANDING SCREEN 24" HIGH CLEAR, 1 7/8" BASE

PART #	HEIGHT	WIDTH	LIST
FPSF2.2424-CL	24"	24"	\$436
FPSF2.2430-CL	24"	30"	\$461
FPSF2.2436-CL	24"	36"	\$487
FPSF2.2442-CL	24"	42"	\$512
FPSF2.2448-CL	24"	48"	\$537
FPSF2.2454-CL	24"	54"	\$563
FPSF2.2460-CL	24"	60"	\$588

Shield Acrylic Screen, Freestanding, 4" Base

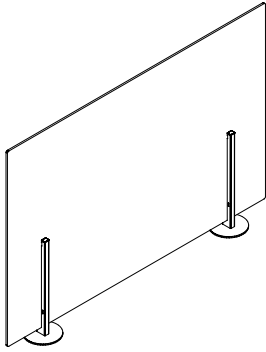

DESCRIPTION

Shield clear acrylic screen with freestanding hardware attachment, 4" base.

NOTES

- Freestanding hardware attaches with removable adhesive
- Round hardware base diameter is 4"
- Hardware is silver
- Clear acrylic screen, 5mm thick
- Actual screen size is less 1/2" high and 1/8" wide
- Sold individually

SPECIFICATION OPTIONS

product #: see charts below

ORDER EXAMPLE

product #: FPSF4.1448-CL

FREESTANDING SCREEN 14" HIGH CLEAR, 4" BASE

PART #	HEIGHT	WIDTH	LIST
FPSF4.1424-CL	14"	24"	\$444
FPSF4.1430-CL	14"	30"	\$459
FPSF4.1436-CL	14"	36"	\$473
FPSF4.1442-CL	14"	42"	\$488
FPSF4.1448-CL	14"	48"	\$503
FPSF4.1454-CL	14"	54"	\$518
FPSF4.1460-CL	14"	60"	\$532

FREESTANDING SCREEN 24" HIGH CLEAR, 4" BASE

PART #	HEIGHT	WIDTH	LIST
FPSF4.2424-CL	24"	24"	\$486
FPSF4.2430-CL	24"	30"	\$511
FPSF4.2436-CL	24"	36"	\$537
FPSF4.2442-CL	24"	42"	\$562
FPSF4.2448-CL	24"	48"	\$587
FPSF4.2454-CL	24"	54"	\$613
FPSF4.2460-CL	24"	60"	\$638

Shield Acrylic Screen, Clamp

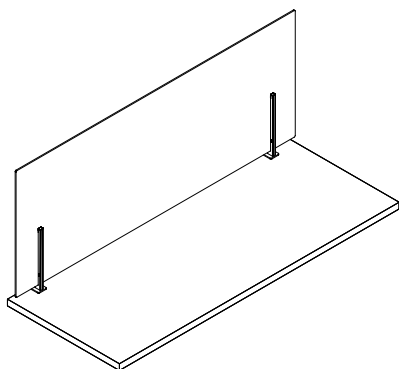

DESCRIPTION

Shield clear acrylic screen with clamp hardware attachment.

NOTES

- Clamp mount package attaches to the edge of a worksurface
- Clamp can be used on surfaces 1"-1.25" thick
- Hardware is silver
- Clear acrylic screen, 5mm thick
- Actual screen size is less 1/2" high and 1/8" wide
- Sold individually

SPECIFICATION OPTIONS

product #: see charts below

ORDER EXAMPLE

product #: FPSC.1448-CL

CLAMP SCREEN 14" HIGH CLEAR

PART #	HEIGHT	WIDTH	LIST
FPSC.1422-CL	14"	22"	\$394
FPSC.1424-CL	14"	24"	\$394
FPSC.1428-CL	14"	28"	\$409
FPSC.1430-CL	14"	30"	\$409
FPSC.1436-CL	14"	36"	\$423
FPSC.1440-CL	14"	40"	\$438
FPSC.1442-CL	14"	42"	\$438
FPSC.1446-CL	14"	46"	\$453
FPSC.1448-CL	14"	48"	\$453
FPSC.1452-CL	14"	52"	\$468
FPSC.1454-CL	14"	54"	\$468
FPSC.1458-CL	14"	58"	\$482
FPSC.1460-CL	14"	60"	\$482

CLAMP SCREEN 24" HIGH CLEAR

PART #	HEIGHT	WIDTH	LIST
FPSC.2422-CL	24"	22"	\$436
FPSC.2424-CL	24"	24"	\$436
FPSC.2428-CL	24"	28"	\$461
FPSC.2430-CL	24"	30"	\$461
FPSC.2436-CL	24"	36"	\$487
FPSC.2440-CL	24"	40"	\$512
FPSC.2442-CL	24"	42"	\$512
FPSC.2446-CL	24"	46"	\$537
FPSC.2448-CL	24"	48"	\$537
FPSC.2452-CL	24"	52"	\$563
FPSC.2454-CL	24"	54"	\$563
FPSC.2458-CL	24"	58"	\$588
FPSC.2460-CL	24"	60"	\$588

Shield Acrylic Screen, Panel-Mounted

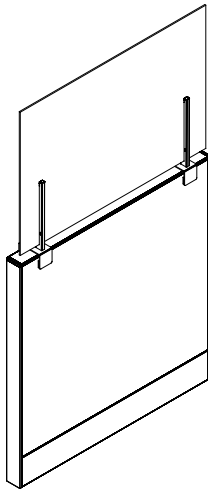

DESCRIPTION

Shield clear acrylic screen with panel-mount hardware attachment.

NOTES

- Panel hardware clamps on to most panels 1.6"-3.6" thick
- Select bracket size:
 - H1 for panels 1.6"-2" thick
 - H2 for panels 2.1"-2.5" thick
 - H3 for panels 2.6"-3" thick
 - H4 for panels 3.1"-3.6" thick
- For System 2 and Novo, use H1 brackets
- For Interra, use H3 brackets
- Hardware is silver
- Clear acrylic screen, 5mm thick
- Actual screen size is less 1/2" high and 1/8" wide
- Screen cannot be used at change of height location. Screen width does not accommodate change of height trim
- Sold individually

SPECIFICATION OPTIONS

product #: see charts below
bracket size: H1-H4, see sizes below

ORDER EXAMPLE

product #: FPSP.1448-CL
bracket size: H1

PANEL SCREEN 14" HIGH CLEAR

PART #	HEIGHT	WIDTH	LIST
FPSP.1424-CL	14"	24"	\$418
FPSP.1430-CL	14"	30"	\$432
FPSP.1436-CL	14"	36"	\$447
FPSP.1442-CL	14"	42"	\$462
FPSP.1448-CL	14"	48"	\$477
FPSP.1454-CL	14"	54"	\$491
FPSP.1460-CL	14"	60"	\$506

PANEL SCREEN 24" HIGH CLEAR

PART #	HEIGHT	WIDTH	LIST
FPSP.2424-CL	24"	24"	\$460
FPSP.2430-CL	24"	30"	\$485
FPSP.2436-CL	24"	36"	\$510
FPSP.2442-CL	24"	42"	\$536
FPSP.2448-CL	24"	48"	\$561
FPSP.2454-CL	24"	54"	\$586
FPSP.2460-CL	24"	60"	\$612

For use with
MY-HITE / UNIVERSAL

Worksurface Mounted Acrylic Screen (NEW)

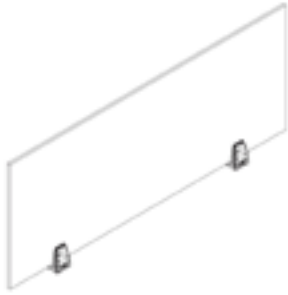

DESCRIPTION

Surface mounted acrylic screens, including hardware

NOTES

- Clear acrylic screen, 8mm thick
- Actual screen size is less 1/2" high and 1/8" wide
- Includes: (2) supporting brackets for screens up to 46"W, (3) supporting brackets for screens 48"W and wider.
- Mounts to any laminate/veneer worksurface top.
- Brackets attach permanently to the work top with bolts

SPECIFICATION OPTIONS

product #: see charts below
paint (brackets): CW, BU, SV

ORDER EXAMPLE

product #: FMHPLSC.1430-CL
paint: SV Silver

14" H CLEAR

PART #	HEIGHT	WIDTH	LIST
FMHPLSC.1422-CL	14"	22"	\$369
FMHPLSC.1424-CL	14"	24"	\$376
FMHPLSC.1428-CL	14"	28"	\$391
FMHPLSC.1430-CL	14"	30"	\$398
FMHPLSC.1436-CL	14"	36"	\$419
FMHPLSC.1440-CL	14"	40"	\$461
FMHPLSC.1442-CL	14"	42"	\$461
FMHPLSC.1446-CL	14"	46"	\$501
FMHPLSC.1448-CL	14"	48"	\$501
FMHPLSC.1452-CL	14"	52"	\$543
FMHPLSC.1454-CL	14"	54"	\$543
FMHPLSC.1458-CL	14"	58"	\$543
FMHPLSC.1460-CL	14"	60"	\$543

16" H CLEAR

PART #	HEIGHT	WIDTH	LIST
FMHPLSC.1622-CL	16"	22"	\$381
FMHPLSC.1624-CL	16"	24"	\$389
FMHPLSC.1628-CL	16"	28"	\$405
FMHPLSC.1630-CL	16"	30"	\$413
FMHPLSC.1636-CL	16"	36"	\$437
FMHPLSC.1640-CL	16"	40"	\$485
FMHPLSC.1642-CL	16"	42"	\$485
FMHPLSC.1646-CL	16"	46"	\$525
FMHPLSC.1648-CL	16"	48"	\$525
FMHPLSC.1652-CL	16"	52"	\$574
FMHPLSC.1654-CL	16"	54"	\$574
FMHPLSC.1658-CL	16"	58"	\$574
FMHPLSC.1660-CL	16"	60"	\$574

Worksurface Mounted Acrylic Screen (NEW)**18" H CLEAR**

PART #	HEIGHT	WIDTH	LIST
FMHPLSC.1822-CL	18"	22"	\$392
FMHPLSC.1824-CL	18"	24"	\$401
FMHPLSC.1828-CL	18"	28"	\$419
FMHPLSC.1830-CL	18"	30"	\$428
FMHPLSC.1836-CL	18"	36"	\$455
FMHPLSC.1840-CL	18"	40"	\$510
FMHPLSC.1842-CL	18"	42"	\$510
FMHPLSC.1846-CL	18"	46"	\$549
FMHPLSC.1848-CL	18"	48"	\$549
FMHPLSC.1852-CL	18"	52"	\$604
FMHPLSC.1854-CL	18"	54"	\$604
FMHPLSC.1858-CL	18"	58"	\$604
FMHPLSC.1860-CL	18"	60"	\$604

24" H CLEAR

PART #	HEIGHT	WIDTH	LIST
FMHPLSC.2422-CL	24"	22"	\$420
FMHPLSC.2424-CL	24"	24"	\$432
FMHPLSC.2428-CL	24"	28"	\$461
FMHPLSC.2430-CL	24"	30"	\$473
FMHPLSC.2436-CL	24"	36"	\$510
FMHPLSC.2440-CL	24"	40"	\$582
FMHPLSC.2442-CL	24"	42"	\$582
FMHPLSC.2446-CL	24"	46"	\$622
FMHPLSC.2448-CL	24"	48"	\$622
FMHPLSC.2452-CL	24"	52"	\$695
FMHPLSC.2454-CL	24"	54"	\$695
FMHPLSC.2458-CL	24"	58"	\$695
FMHPLSC.2460-CL	24"	60"	\$695

Worksurface Mounted Screens, Fabric (NEW)

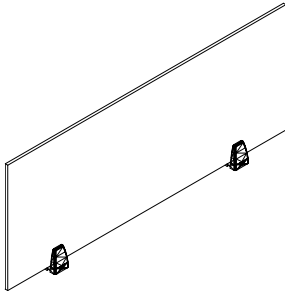

DESCRIPTION

Surface mounted fabric screens, including hardware

SPECIFICATION OPTIONS

product #: see charts below
Paint (Brackets) CW, BU, SV
fabric: see page 7 (Passage and Terrain fabric not approved for this application)

NOTES

- Includes: (2) supporting brackets for screens up to 42"W, (3) supporting brackets for screens 48"W and wider.
- Mounts to any laminate/veneer worksurface top.
- Brackets attach permanently to the work top with bolts

ORDER EXAMPLE

product #: FWSMTK.1424
paint: SV Silver
fabric: PF-101-2 Slide, Slate

Fabric Screens, 14" HIGH

PART #	HEIGHT	WIDTH	LIST
FWSMTK.1424	14"	24"	\$242
FWSMTK.1430	14"	30"	\$255
FWSMTK.1436	14"	36"	\$306
FWSMTK.1442	14"	42"	\$306
FWSMTK.1448	14"	48"	\$354
FWSMTK.1454	14"	54"	\$431
FWSMTK.1460	14"	60"	\$455
FWSMTK.1466	14"	66"	\$455
FWSMTK.1472	14"	72"	\$480

NOTES

- Screen mounts to any laminate/veneer worksurface top

Fabric Screens, 14" HIGH

PART #	HEIGHT	WIDTH	LIST
FWSMTK.1422	14"	22"	\$242
FWSMTK.1428	14"	28"	\$255

NOTES

- Screen mounts to any laminate/veneer worksurface top

Fabric Screens, 24" HIGH

PART #	HEIGHT	WIDTH	LIST
FWSMTK.2422	24"	22"	\$489
FWSMTK.2424	24"	24"	\$492
FWSMTK.2428	24"	28"	\$514
FWSMTK.2430	24"	30"	\$517
FWSMTK.2436	24"	36"	\$603
FWSMTK.2442	24"	42"	\$631
FWSMTK.2448	24"	48"	\$703
FWSMTK.2454	24"	54"	\$807
FWSMTK.2460	24"	60"	\$880
FWSMTK.2466	24"	66"	\$889
FWSMTK.2472	24"	72"	\$962

NOTES

- Screen mounts to any laminate/veneer worksurface top

Worksurface Mounted Glass Screens, Clear

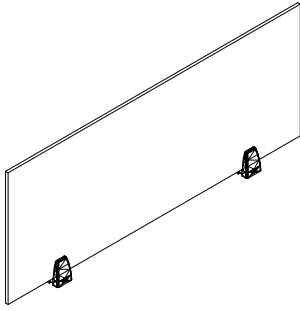

DESCRIPTION

Surface mounted glass screens, including hardware.

NOTES

- Actual screen size is less 1/2" high and 3/4" wide
- Includes: (2) supporting brackets for screens up to 42"W, (3) supporting brackets for screens 48"W and wider.
- Mounts to any laminate/veneer worksurface top.
- Brackets attach permanently to the work top with bolts

SPECIFICATION OPTIONS

product # see charts below
Paint (Brackets) CW, BU, SV

ORDER EXAMPLE

product #: FWSMG.0824-CL
paint: SV Silver

8" HIGH

PART #	HEIGHT	WIDTH	LIST
FWSMG.0824-CL	8"	24"	\$145
FWSMG.0830-CL	8"	30"	\$157
FWSMG.0836-CL	8"	36"	\$169
FWSMG.0842-CL	8"	42"	\$181
FWSMG.0848-CL	8"	48"	\$193
FWSMG.0854-CL	8"	54"	\$253
FWSMG.0860-CL	8"	60"	\$265
FWSMG.0866-CL	8"	66"	\$277
FWSMG.0872-CL	8"	72"	\$288

NOTES

- Screen mounts to any laminate/veneer worksurface top

14" HIGH

PART #	HEIGHT	WIDTH	LIST
FWSMG.1424-CL	14"	24"	\$182
FWSMG.1430-CL	14"	30"	\$202
FWSMG.1436-CL	14"	36"	\$221
FWSMG.1442-CL	14"	42"	\$240
FWSMG.1448-CL	14"	48"	\$261
FWSMG.1454-CL	14"	54"	\$330
FWSMG.1460-CL	14"	60"	\$348
FWSMG.1466-CL	14"	66"	\$366
FWSMG.1472-CL	14"	72"	\$384

NOTES

- Screen mounts to any laminate/veneer worksurface top

15" HIGH

PART #	HEIGHT	WIDTH	LIST
FWSMG.1522-CL	15"	22"	\$249
FWSMG.1528-CL	15"	28"	\$265

Worksurface Mounted Glass Screens, Frosted

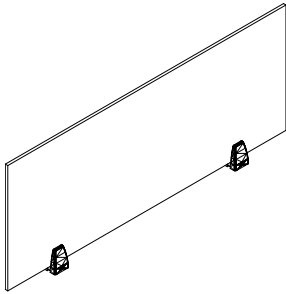

DESCRIPTION

Surface mounted glass screens, including hardware

NOTES

- Actual screen size is less 1/2" high and 3/4" wide
- Includes: (2) supporting brackets for screens up to 42"W, (3) supporting brackets for screens 48"W and wider.
- Mounts to any laminate/veneer worksurface top.
- Brackets attach permanently to the worktop with bolts

SPECIFICATION OPTIONS

product #: see charts below
Paint (Brackets) CW, BU, SV

ORDER EXAMPLE

product #: FWSMG.0824-FR
paint: SV Silver

8" HIGH

PART #	HEIGHT	WIDTH	LIST
FWSMG.0824-FR	8"	24"	\$203
FWSMG.0830-FR	8"	30"	\$230
FWSMG.0836-FR	8"	36"	\$257
FWSMG.0842-FR	8"	42"	\$285
FWSMG.0848-FR	8"	48"	\$312
FWSMG.0854-FR	8"	54"	\$364
FWSMG.0860-FR	8"	60"	\$374
FWSMG.0866-FR	8"	66"	\$384
FWSMG.0872-FR	8"	72"	\$394

NOTES

- Screen mounts to any laminate/veneer worksurface top

14" HIGH

PART #	HEIGHT	WIDTH	LIST
FWSMG.1424-FR	14"	24"	\$284
FWSMG.1430-FR	14"	30"	\$331
FWSMG.1436-FR	14"	36"	\$377
FWSMG.1442-FR	14"	42"	\$422
FWSMG.1448-FR	14"	48"	\$470
FWSMG.1454-FR	14"	54"	\$524
FWSMG.1460-FR	14"	60"	\$564
FWSMG.1466-FR	14"	66"	\$603
FWSMG.1472-FR	14"	72"	\$643

NOTES

- Screen mounts to any laminate/veneer worksurface top

15" HIGH

PART #	HEIGHT	WIDTH	LIST
FWSMG.1522-FR	15"	22"	\$346
FWSMG.1528-FR	15"	28"	\$387

Privacy Screen, Fabric

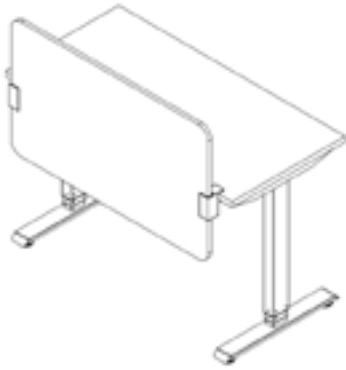

DESCRIPTION

Work Surface mounted fabric covered privacy screen

NOTES

- Fabric screen is non-tackable
- To use a wire manager on your My-Hite table with a fabric covered privacy screen, you must order "with gap".
- Actual screen is shorter than the worktop.
- Example: FPSFLUSH.2448 for use on 46"/48" width table, actual width of screen is 40".
- **Passage and Terrain fabric not approved for this application**

SPECIFICATION OPTIONS

product # see charts below
Paint (Brackets): CW, BU, SV
fabric: see page 7 (Passage and Terrain fabric not approved for this application)

ORDER EXAMPLE

product #: FPSFLUSH.2448
brackets: SV, Silver
fabric: PF-101-2 Slide, Slate

Fabric Privacy Screen - Flush

Have grommet? Go flush

PART #	HEIGHT	WIDTH	LIST
FPSFLUSH.2442	24"	34"	\$480
FPSFLUSH.2448	24"	40"	\$520
FPSFLUSH.2454	24"	46"	\$560
FPSFLUSH.2460	24"	52"	\$601
FPSFLUSH.2466	24"	58"	\$642
FPSFLUSH.2472	24"	64"	\$683

NOTES

- Privacy screen sits flush with the back of the worktop.
- Privacy screen is 8" shorter than free standing top width and 6" shorter than a worksurface from a paneled system.
- Example:
- FSQAHT-2460 order FPSFLUSH.2460 (actual width 52')

Fabric Privacy Screen with Wire Management Gap

Need space between the screen and top? Add gap

PART #	HEIGHT	WIDTH	LIST
FPSGAP.2442	24"	34"	\$480
FPSGAP.2448	24"	40"	\$520
FPSGAP.2454	24"	46"	\$560
FPSGAP.2460	24"	52"	\$601
FPSGAP.2466	24"	58"	\$642
FPSGAP.2472	24"	64"	\$683

NOTES

- With 1" gap at back of worksurface for cord/wire management.
- Example:
1. FSQAHT-2460 order FPSGAP.2460 (actual width 52')
- Privacy screen sits flush with the back of the worktop.
 - Privacy screen is 8" shorter than free standing top width and 6" shorter than a worksurface from a paneled system.
- Example:
1. FSQAHT-2460 order FPSGAP.2460 (actual width 52')

Privacy Screen, Marker Board

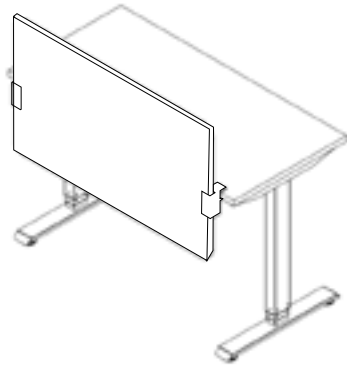

DESCRIPTION

Work Surface mounted marker board privacy screen

NOTES

- To use a wire manager on your My-Hite table with a marker board privacy screen, you must order "with gap".
- Actual screen is shorter than the worktop.
- Example: FMPSFLUSH.2448 for use on 46"/48" width table, actual width of screen is 40"

SPECIFICATION OPTIONS

product #: see charts below
Paint (Brackets): CW, BU, SV

ORDER EXAMPLE

product #: FMPSFLUSH.2448
brackets: SV, Silver

Marker Board Privacy Screen - Flush

Have grommet? Go flush

PART #	HEIGHT	WIDTH	LIST
FMPSFLUSH.2442	24"	34"	\$621
FMPSFLUSH.2448	24"	40"	\$711
FMPSFLUSH.2454	24"	46"	\$801
FMPSFLUSH.2460	24"	52"	\$892
FMPSFLUSH.2466	24"	58"	\$982
FMPSFLUSH.2472	24"	64"	\$1,073

NOTES

- Privacy screen sits flush with the back of the worktop.
- Privacy screen is 8" shorter than free standing top width and 6" shorter than a worksurface from a paneled system.

Example:

1. FSQAHT-2460 order FMPSFLUSH.2460 (actual width 52')

Marker Board Privacy Screen- with Wire Management Gap

Need space between the screen and top? Add gap

PART #	HEIGHT	WIDTH	LIST
FMPGAP.2442	24"	34"	\$621
FMPGAP.2448	24"	40"	\$711
FMPGAP.2454	24"	46"	\$801
FMPGAP.2460	24"	52"	\$892
FMPGAP.2466	24"	58"	\$982
FMPGAP.2472	24"	64"	\$1,073

NOTES

- With 1" gap at back of worksurface for cord/wire management.

Example:

1. FSQAHT-2460 order FMPGAP.2460 (actual width 52')
- Privacy screen sits flush with the back of the worktop.
 - Privacy screen is 8" shorter than free standing top width and 6" shorter than a worksurface from a paneled system.
- Example:
1. FSQAHT-2460 order FMPGAP.2460 (actual width 52')

Privacy Screen, Laminate

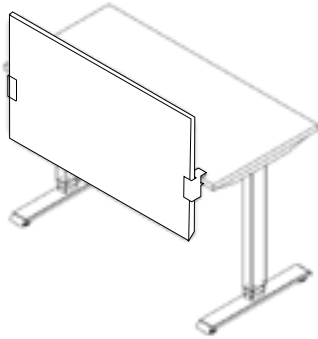

DESCRIPTION

Work Surface mounted laminate privacy screen

NOTES

- To use a wire manager on your My-Hite table with a laminate privacy screen, you must order "with gap".
- Actual screen is shorter than the worktop.

SPECIFICATION OPTIONS

product #: see charts below
paint (brackets): CW, BU, SV
surface finish: see page 9

ORDER EXAMPLE

product #: FLPSFLUSH.2442
paint: SV Silver
surface finish: M10 Espresso

Laminate Privacy Screen - Flush

Have grommet? Go flush

PART #	HEIGHT	WIDTH	LIST
FLPSFLUSH.2442	24"	34"	\$327
FLPSFLUSH.2448	24"	40"	\$364
FLPSFLUSH.2454	24"	46"	\$400
FLPSFLUSH.2460	24"	52"	\$436
FLPSFLUSH.2466	24"	58"	\$473
FLPSFLUSH.2472	24"	64"	\$509

NOTES

- Privacy screen sits flush with the back of the worktop.
- Privacy screen is 8" shorter than free standing top width and 6" shorter than a worksurface from a paneled system.

Example:

1. FSQAHT-2460 order FPSFLUSH.2460 (actual width 52")

Laminate Privacy Screen - with Wire Management Gap

Need space between the screen and top? Add gap

PART #	HEIGHT	WIDTH	LIST
FLPSGAP.2442	24"	34"	\$327
FLPSGAP.2448	24"	40"	\$364
FLPSGAP.2454	24"	46"	\$400
FLPSGAP.2460	24"	52"	\$436
FLPSGAP.2466	24"	58"	\$473
FLPSGAP.2472	24"	64"	\$509

NOTES

- With 1" gap at back of worksurface for cord/wire management.

Example:

1. FSQAHT-2460 order FPSGAP.2460 (actual width 52")

- Privacy screen sits flush with the back of the worktop.
- Privacy screen is 8" shorter than free standing top width and 6" shorter than a worksurface from a paneled system.

Example:

1. FSQAHT-2460 order FLPSGAP.2460 (actual width 52")

For use with
VERITY

Supporting Cabinets

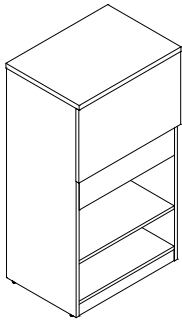

DESCRIPTION

Storage support elements on one side.

SPECIFICATION OPTIONS

product #: see charts below
front, casing & worksurface finish (if applicable): See surface laminates on page 9
fabric: See page 7

NOTES

- Order storage attachment bracket separately (see Verity pricebook).
- Specify worksurface finish for top and for casing
- Specify fabric on page 7

ORDER EXAMPLE

product #: FVWSTT.1824
front finish: M1 Light Maple
worksurface finish: M1 Light Maple
casing finish: M29 Raven
fabric: PF401-Silky-Natural

Tackboard & Bookcase

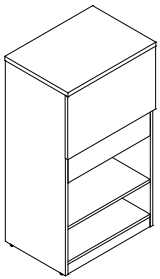

front shown

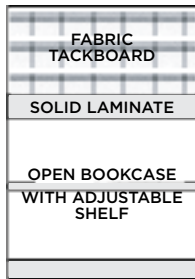

FRONT

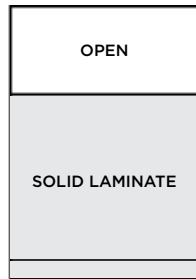

BACK

PART #	HEIGHT	WIDTH	DEPTH	WT. (LBS)	LIST
FVWSTT.1824	45"	24.75"	18"	—	\$1,063
FVWSTT.1830	45"	30.75"	18"	—	\$1,223

NOTES

Supporting laminate cabinets with tackboard top and open bookcase bottom on one side, with open top and solid surface on the opposite side. Specify fabric for tackboard.

Open & Bookcase

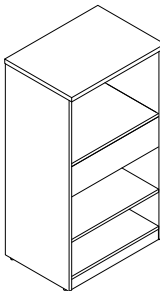

front shown

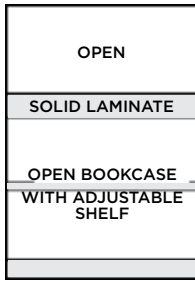

FRONT



BACK

PART #	HEIGHT	WIDTH	DEPTH	WT. (LBS)	LIST
FVWSTO.1824	45"	24.75"	18"	—	\$889
FVWSTO.1830	45"	30.75"	18"	—	\$986

NOTES

Supporting laminate cabinets with open top and open bookcase bottom on one side, with solid surface on the opposite side.

Tackboard & Shared Bookcase

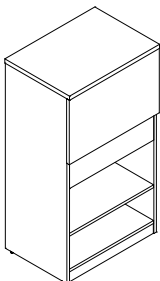

front shown

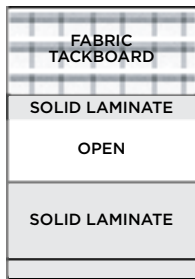

FRONT

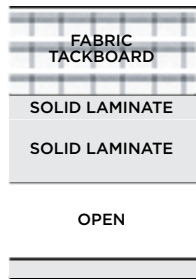

BACK

PART #	HEIGHT	WIDTH	DEPTH	WT. (LBS)	LIST
FVWSTS.1824	45"	24.75"	18"	—	\$1,142
FVWSTS.1830	45"	30.75"	18"	—	\$1,343

NOTES

Supporting laminate cabinets with tackboard top and shared bookcase bottom on both sides. Shared bookcase has one open shelf and one solid surface on each side. Specify fabric for tackboard.

Over-Worksurface Storage, Single-Sided

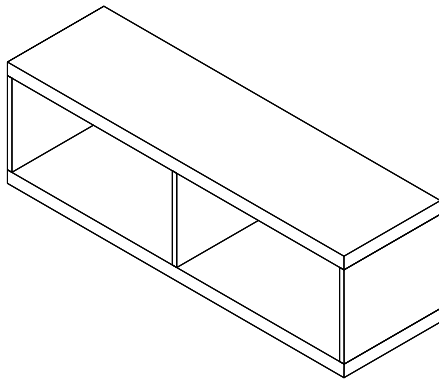

DESCRIPTION

Single-sided laminate storage that is mounted above the worksurface, perpendicular to the spine. Available with open shelf or sliding door.

NOTES

- Specify support (post leg or cabinet) separately
- Specify front finish and left/right pull location for storage door (if applicable)
- Specify pull when ordering
- Designer pull has color options: specify color when ordering.

SPECIFICATION OPTIONS

product #: see charts below
front finish: see page 9
top finish: see page 9
casing finish: see page 9
left or right (if applicable): L for Left, R for Right
pull: See below

ORDER EXAMPLE

product #: FVOSDSN.1524
front finish: M1 Light Maple
top finish: M1 Light Maple
casing finish: M1 Light Maple
left or right (if applicable): L for Left
pull: Wedge

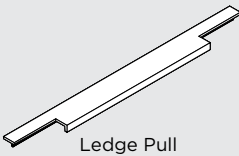
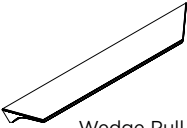
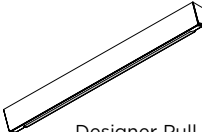
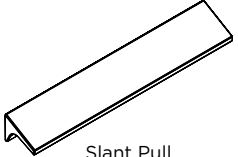
	DEFAULT PULL	PREMIUM PULLS		
STORAGE PULL OPTIONS	 Ledge Pull	 Wedge Pull	 Designer Pull • Cloud White/Red • Cloud White/Green • Cloud White/Grey	 Slant Pull

WITH SLIDING DOOR 15" HIGH

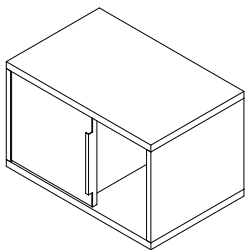

right hand shown

PART #	HEIGHT	WIDTH	DEPTH	WT. (LBS)	LIST	NOTES
FVOSDSN.1524L	15"	24"	13.75"	—	\$535	Laminate storage with sliding door and solid back
FVOSDSN.1524R	15"	24"	13.75"	—	\$535	
FVOSDSN.1530L	15"	30"	13.75"	—	\$591	Specify L for left or R for right indicating door pull location.
FVOSDSN.1530R	15"	30"	13.75"	—	\$591	
FVOSDSN.1548L	15"	48"	13.75"	—	\$773	Specify front finish for sliding door
FVOSDSN.1548R	15"	48"	13.75"	—	\$773	
FVOSDSN.1560L	15"	60"	13.75"	—	\$999	Specify pull when ordering
FVOSDSN.1560R	15"	60"	13.75"	—	\$999	
FVOSDSN.1572L	15"	72"	13.75"	—	\$1,084	
FVOSDSN.1572R	15"	72"	13.75"	—	\$1,084	

**WITH OPEN SHELF
15" HIGH**

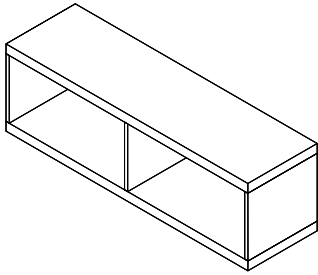

PART #	HEIGHT	WIDTH	DEPTH	WT. (LBS)	LIST
FVOSOSN.1524	15"	24"	13.75"	—	\$291
FVOSOSN.1530	15"	30"	13.75"	—	\$379
FVOSOSN.1548	15"	48"	13.75"	—	\$528
FVOSOSN.1560	15"	60"	13.75"	—	\$619
FVOSOSN.1572	15"	72"	13.75"	—	\$699

NOTES

Laminate storage with open shelf, and solid back
 24"W and 30"W do not have a center divider.
 48"W or wider have a center divider.

**WITH OPEN SHELF
8" HIGH**

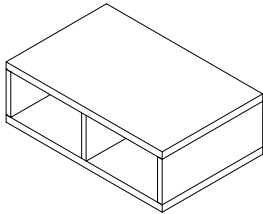

PART #	HEIGHT	WIDTH	DEPTH	WT. (LBS)	LIST
FVOSOS.0824	8"	24"	13.75"	—	\$194
FVOSOS.0830	8"	30"	13.75"	—	\$226
FVOSOS.0848	8"	48"	13.75"	—	\$354
FVOSOS.0860	8"	60"	13.75"	—	\$417
FVOSOS .0872	8"	72"	13.75"	—	\$473

NOTES

Laminate storage with open shelf, open back and center divider.
 24"W and 30"W do not have a center divider.
 48"W or wider have a center divider.

Over-Worksurface Storage, Double-Sided

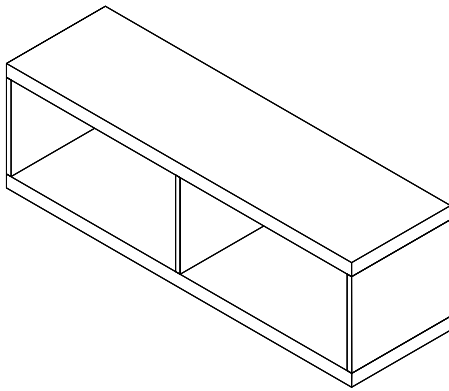

DESCRIPTION

Double-sided (shared) storage that is mounted above the worksurface, perpendicular to the spine. Available with open shelf, or sliding door and markerboard.

NOTES



- Specify support (post leg or cabinet) separately
- Specify front finish and left/right pull location for storage door (if applicable)
- Specify pull when ordering
- Designer pull has color options: specify color when ordering.

SPECIFICATION OPTIONS

product #: see charts below
front finish: see page 9
top finish: see page 9
casing finish: see page 9
left or right (if applicable): L for Left, R for Right
pull: See below

ORDER EXAMPLE

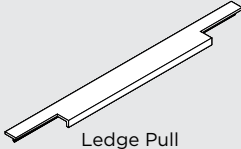
product #: FVOSDSH.1524
front finish: M1 Light Maple
top finish: M1 Light Maple
casing finish: M1 Light Maple
left or right (if applicable): L for Left
pull: Wedge

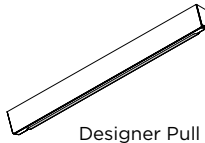
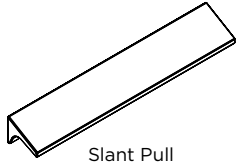
	DEFAULT PULL	PREMIUM PULLS		
STORAGE PULL OPTIONS	 Ledge Pull	 Wedge Pull	 Designer Pull • Cloud White/Red • Cloud White/Green • Cloud White/Grey	 Slant Pull

WITH SLIDING DOOR 15" HIGH

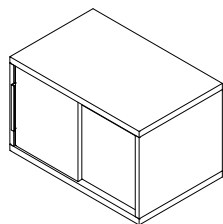

left hand shown

PART #	HEIGHT	WIDTH	DEPTH	WT. (LBS)	LIST	NOTES
FVOSDSH.1524L	15"	24"	13.75"	—	\$856	Laminate storage with sliding door and markerboard on each side
FVOSDSH.1524R	15"	24"	13.75"	—	\$856	
FVOSDSH.1530L	15"	30"	13.75"	—	\$953	Specify L for left or R for right indicating door pull location.
FVOSDSH.1530R	15"	30"	13.75"	—	\$953	
FVOSDSH.1548L	15"	48"	13.75"	—	\$1,273	Specify front finish for sliding door.
FVOSDSH.1548R	15"	48"	13.75"	—	\$1,273	
FVOSDSH.1560L	15"	60"	13.75"	—	\$1,464	Specify pull when ordering
FVOSDSH.1560R	15"	60"	13.75"	—	\$1,464	
FVOSDSH.1572L	15"	72"	13.75"	—	\$1,612	Designer pull has color options: specify color when ordering.
FVOSDSH.1572R	15"	72"	13.75"	—	\$1,612	

**WITH OPEN SHELF
15" HIGH**

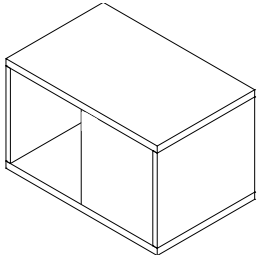

left hand shown

PART #	HEIGHT	WIDTH	DEPTH	WT. (LBS)	LIST
FVOSOSH.1524L	15"	24"	13.75"	—	\$262
FVOSOSH.1524R	15"	24"	13.75"	—	\$262
FVOSOSH.1530L	15"	30"	13.75"	—	\$262
FVOSOSH.1530R	15"	30"	13.75"	—	\$262
FVOSOSH.1548L	15"	48"	13.75"	—	\$435
FVOSOSH.1548R	15"	48"	13.75"	—	\$435
FVOSOSH.1560L	15"	60"	13.75"	—	\$471
FVOSOSH.1560R	15"	60"	13.75"	—	\$471
FVOSOSH.1572L	15"	72"	13.75"	—	\$526
FVOSOSH.1572R	15"	72"	13.75"	—	\$526

NOTES

Laminate storage with open shelf and markerboard on each side.
Specify L for left or R for right indicating open shelf location.

**WITH OPEN SHELF
8" HIGH**

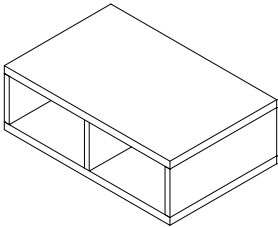

PART #	HEIGHT	WIDTH	DEPTH	WT. (LBS)	LIST
FVOSOS.0824	8"	24"	13.75"	—	\$194
FVOSOS.0830	8"	30"	13.75"	—	\$226
FVOSOS.0848	8"	48"	13.75"	—	\$354
FVOSOS.0860	8"	60"	13.75"	—	\$417
FVOSOS.0872	8"	72"	13.75"	—	\$473

NOTES

Laminate storage with open shelf, open back and center divider.
24"W and 30"W do not have a center divider.
48"W or wider have a center divider.

**SUPPORT COLUMN LEG
WITH DISC BASE**

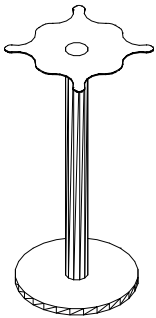

PART #	HEIGHT	WIDTH	DEPTH	WT. (LBS)	LIST
FVSL.3	29.5"	3"/14"	—	—	\$430

NOTES

Supporting column leg with disc base for over-worksurface mounted cabinets.
3"W column, 14"W disc base.
Supporting leg available in paint finish

SUPPORT CABINET

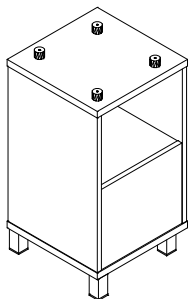

PART #	HEIGHT	WIDTH	DEPTH	WT. (LBS)	LIST
FVSC.1416	29.5"	15.5"	13.75"	—	\$765

NOTES

Supporting cabinet for over-worksurface mounted cabinets.
Specify top,casing and front finish
Opposite side is closed at top and open at bottom.

Track Mounted Fabric Screen

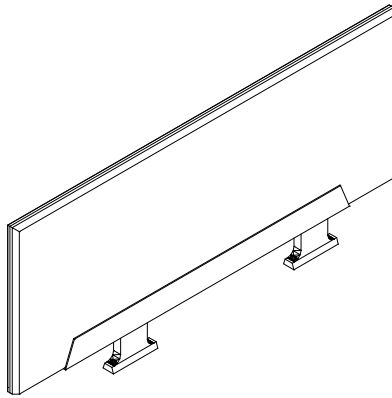

DESCRIPTION

Accessories mounted to the center track.
Please view individual product details below.

SPECIFICATION OPTIONS

product #: see charts below
fabric (if applicable): see page 7
(Passage and Terrain fabric not approved for this application)
paint (bracket): CW, BU, or SV

NOTES

Mounts to Verity track
Support brackets available in CW, BU and SV
A shelf cannot be installed in the same position as the track mounted tackboard.

ORDER EXAMPLE

product #: FVTKBDT.1560
fabric: PF-101-2 Slide, Slate
paint: CW Cloud White

Passage and Terrain fabric not approved for this application

FABRIC TACKBOARD 15" (track-mounted)

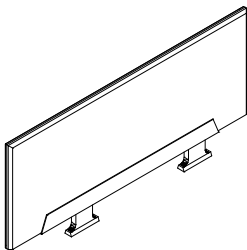

PART #	HEIGHT	WIDTH	DEPTH	WT. (LBS)	LIST
FVTKBDT.1536	15"	34"	1.25"	—	\$322
FVTKBDT.1542	15"	40"	1.25"	—	\$362
FVTKBDT.1548	15"	46"	1.25"	—	\$390
FVTKBDT.1554	15"	52"	1.25"	—	\$459
FVTKBDT.1560	15"	58"	1.25"	—	\$496
FVTKBDT.1566	15"	64"	1.25"	—	\$535
FVTKBDT.1572	15"	70"	1.25"	—	\$558

NOTES
Specify fabric on pg 6.

FABRIC TACKBOARD 18" (track-mounted)

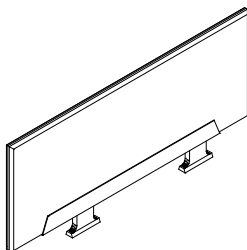

PART #	HEIGHT	WIDTH	DEPTH	WT. (LBS)	LIST
FVTKBDT.1836	18"	34"	1.25"	—	\$354
FVTKBDT.1842	18"	40"	1.25"	—	\$397
FVTKBDT.1848	18"	46"	1.25"	—	\$429
FVTKBDT.1854	18"	52"	1.25"	—	\$505
FVTKBDT.1860	18"	58"	1.25"	—	\$546
FVTKBDT.1866	18"	64"	1.25"	—	\$599
FVTKBDT.1872	18"	70"	1.25"	—	\$614

NOTES
Specify fabric on pg 6.
Support brackets are available in Cloud White, Silver and Black Umber.

FABRIC TACKBOARD 20" (track-mounted)

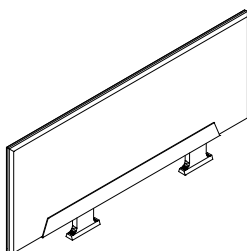

PART #	HEIGHT	WIDTH	DEPTH	WT. (LBS)	LIST
FVTKBDT.2036	20"	34"	1.25"	—	\$370
FVTKBDT.2042	20"	40"	1.25"	—	\$416
FVTKBDT.2048	20"	46"	1.25"	—	\$449
FVTKBDT.2054	20"	52"	1.25"	—	\$527
FVTKBDT.2060	20"	58"	1.25"	—	\$571
FVTKBDT.2066	20"	64"	1.25"	—	\$615
FVTKBDT.2072	20"	70"	1.25"	—	\$642

NOTES
Specify fabric on pg 6.
Support brackets are available in Cloud White, Silver and Black Umber.

Track-Mounted Glass Screen

CLEAR GLASS SCREEN (track-mounted)

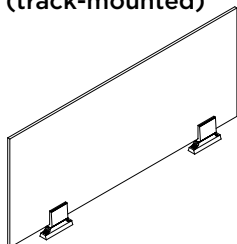

PART #	HEIGHT	WIDTH	DEPTH	WT. (LBS)	LIST
FVGSTCL.1524	15"	23.25"	1.25"	—	\$184
FVGSTCL.1530	15"	29.25"	1.25"	—	\$211
FVGSTCL.1536	15"	35.25"	1.25"	—	\$237
FVGSTCL.1542	15"	41.25"	1.25"	—	\$261
FVGSTCL.1548	15"	47.25"	1.25"	—	\$289
FVGSTCL.1554	15"	53.25"	1.25"	—	\$340
FVGSTCL.1560	15"	59.25"	1.25"	—	\$340
FVGSTCL.1566	15"	65.25"	1.25"	—	\$385
FVGSTCL.1572	15"	71.25"	1.25"	—	\$385

NOTES
Glass is clear.
For 78" tops, order 1 piece of 42" glass and 1 piece of 36" glass.
For 84" tops, order 2 pieces of 42" glass.
For 96" tops, order 2 pieces of 48" glass.

FROSTED GLASS SCREEN (track-mounted)

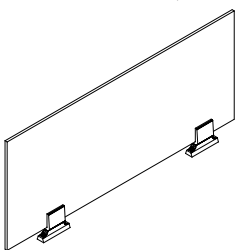

PART #	HEIGHT	WIDTH	DEPTH	WT. (LBS)	LIST
FVGSTFR.1524	15"	23.25"	1.25"	—	\$279
FVGSTFR.1530	15"	29.25"	1.25"	—	\$331
FVGSTFR.1536	15"	35.25"	1.25"	—	\$380
FVGSTFR.1542	15"	41.25"	1.25"	—	\$431
FVGSTFR.1548	15"	47.25"	1.25"	—	\$483
FVGSTFR.1554	15"	53.25"	1.25"	—	\$613
FVGSTFR.1560	15"	59.25"	1.25"	—	\$613
FVGSTFR.1566	15"	65.25"	1.25"	—	\$714
FVGSTFR.1572	15"	71.25"	1.25"	—	\$714

NOTES
Glass is frosted.
For 78" tops, order 1 piece of 42" glass and 1 piece of 36" glass.
For 84" tops, order 2 pieces of 42" glass.
For 96" tops, order 2 pieces of 48" glass.

Track Mounted Acrylic Screen (NEW)

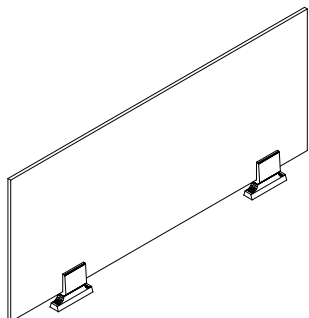

DESCRIPTION

Track mounted acrylic screens, including hardware

NOTES

- Mounts to Verity track
- Clear acrylic screen, 8mm thick
- Actual screen size is less 1/2" high and 1/8" wide

SPECIFICATION OPTIONS

product #: see charts below
paint (brackets): CW, BU, SV

ORDER EXAMPLE

product #: FVSMPLSC.2422-CL
paint: CW Cloud White

24" H CLEAR

PART #	HEIGHT	WIDTH	LIST
FVTMPLSC.2424-CL	24"	24"	\$416
FVTMPLSC.2430-CL	24"	30"	\$454
FVTMPLSC.2436-CL	24"	36"	\$493
FVTMPLSC.2442-CL	24"	42"	\$531
FVTMPLSC.2448-CL	24"	48"	\$570
FVTMPLSC.2454-CL	24"	54"	\$608
FVTMPLSC.2460-CL	24"	60"	\$647
FVTMPLSC.2466-CL	24"	66"	\$685
FVTMPLSC.2472-CL	24"	72"	\$724

Worksurface Mounted Acrylic Screen (NEW)

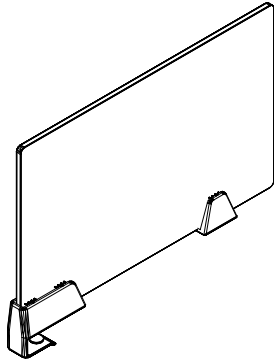

DESCRIPTION

Surface mounted acrylic screens, including hardware

NOTES

- Removable worksurface screen with clamp
- Clear acrylic screen, 8mm thick
- Actual screen size is less 1/2" high and 1/8" wide

SPECIFICATION OPTIONS

product #: see charts below

edge finish: see page 9

worksurface finish: see page 9

ORDER EXAMPLE

product #: FVSMP LSC.2422-CL

24" H CLEAR

PART #	HEIGHT	WIDTH	LIST
FVSMP LSC.2422-CL	24"	22"	\$400
FVSMP LSC.2428-CL	24"	28"	\$438

Worksurface-Mounted Fabric Tackboard

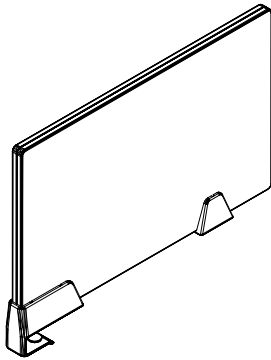

DESCRIPTION

Accessories mounted to the worksurface.

SPECIFICATION OPTIONS

product #: see charts below
fabric: See page 7 (Passage and Terrain fabric not approved for this application).
finish: CW, BU, SV

NOTES

- Removable worksurface screen with clamp

ORDER EXAMPLE

product #: FVTKBDW.1522
fabric: PF401-1 Silky-Natural
finish: CW Cloud White

FABRIC TACKBOARD 15" (surface-mounted)

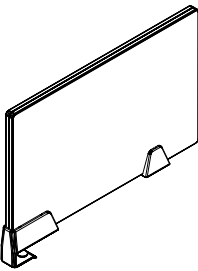

PART #	HEIGHT	WIDTH	DEPTH	WT. (LBS)	LIST
FVTKBDW.1522	15"	22"	1"	—	\$216
FVTKBDW.1528	15"	28"	1"	—	\$267

FABRIC TACKBOARD 18" (surface-mounted)

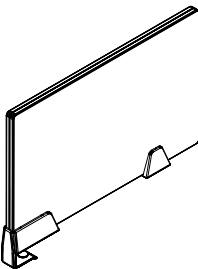

PART #	HEIGHT	WIDTH	DEPTH	WT. (LBS)	LIST
FVTKBDW.1822	18"	22"	1"	—	\$238
FVTKBDW.1828	18"	28"	1"	—	\$293

FABRIC TACKBOARD 20" (surface-mounted)

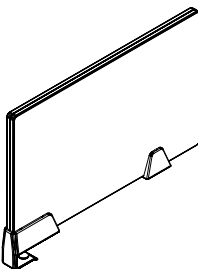

PART #	HEIGHT	WIDTH	DEPTH	WT. (LBS)	LIST
FVTKBDW.2022	20"	22"	1"	—	\$248
FVTKBDW.2028	20"	28"	1"	—	\$306

Worksurface-Mounted Glass Screen

CLEAR GLASS SCREEN (surface-mounted)

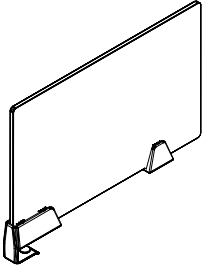

PART #	HEIGHT	WIDTH	DEPTH	WT. (LBS)	LIST	NOTES
FVGSWCL.1522	15"	22"	1"	—	\$237	Glass is clear.
FVGSWCL.1528	15"	28"	1"	—	\$295	Includes hardware.

FROSTED GLASS SCREEN (surface-mounted)

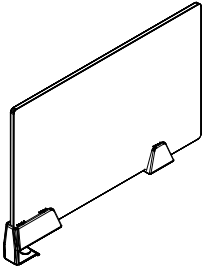

PART #	HEIGHT	WIDTH	DEPTH	WT. (LBS)	LIST	NOTES
FVGSWFR.1522	15"	22"	1"	—	\$327	Glass is frosted.
FVGSWFR.1528	15"	28"	1"	—	\$367	Includes hardware.

MARKERBOARD SCREEN (surface-mounted)

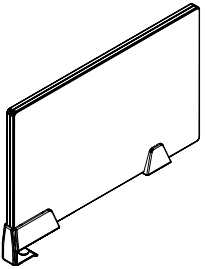

PART #	HEIGHT	WIDTH	DEPTH	WT. (LBS)	LIST	NOTES
FVMKRW.1522	15"	22"	1"	—	\$323	Markerboard with write and erase surface.
FVMKRW.1528	15"	28"	1"	—	\$419	Includes hardware.

For use with
INTERRA

Stacking Frames

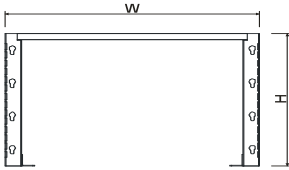
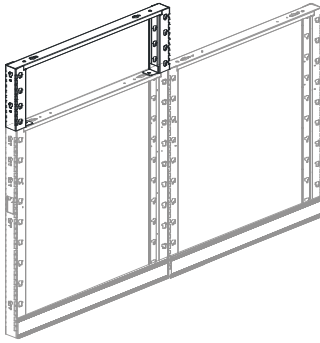

DESCRIPTION

Stacking Frame attaches to the top of a Standard Frame, and holds individual tiles on both sides.

SPECIFICATION OPTIONS

product #: see charts below

NOTES

- Up to two stacking frames can be added to a base frame for a combined height of 45, 53, 61, 69, or 85
- Specify connector to match combined height
- Order change of height trim if needed
- One stacking frame IS load bearing if next to a connector of another frame of equal height
- Two stacking frames are NOT load bearing and must be placed adjacent to another frame or connector of the same height or taller
- Attachment hardware included
- Top cap from base frame is installed on stacking frame
- Stacking frames can accept fabric, perforated metal, stacking window, or rail tiles only

ORDER EXAMPLE

product #: FISF.1624

PART #	HEIGHT	WIDTH	DEPTH	PRICE
FISF.1624	16-3/4"	24"	1-11/16"	\$68
FISF.1630	16-3/4"	30"	1-11/16"	\$71
FISF.1636	16-3/4"	36"	1-11/16"	\$74
FISF.1642	16-3/4"	42"	1-11/16"	\$77
FISF.1648	16-3/4"	48"	1-11/16"	\$81

NOTES

Stacking frames can accept fabric, perforated metal, stacking window, or rail tiles only

Perforated Metal Tile

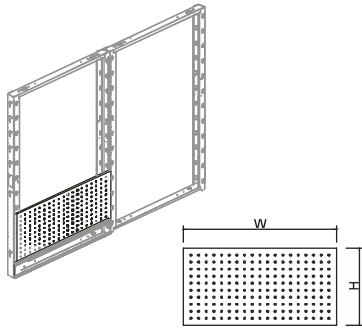

DESCRIPTION

Perforated Metal Tile has round holes. It attaches to one side of a frame.

NOTES

- Surface is magnetic.
- Tile may be placed at any position along the frame.

SPECIFICATION OPTIONS

product #: see charts below
paint: CW, BU SV

ORDER EXAMPLE

product #: FIPMT.0824
paint: CW

8"H

PART #	HEIGHT	WIDTH	DEPTH	PRICE
FIPMT.0824	8"	24"	7/16"	\$47
FIPMT.0830	8"	30"	7/16"	\$53
FIPMT.0836	8"	36"	7/16"	\$60
FIPMT.0842	8"	42"	7/16"	\$66
FIPMT.0848	8"	48"	7/16"	\$74

16"H

PART #	HEIGHT	WIDTH	DEPTH	PRICE
FIPMT.1624	16"	24"	7/16"	\$78
FIPMT.1630	16"	30"	7/16"	\$92
FIPMT.1636	16"	36"	7/16"	\$104
FIPMT.1642	16"	42"	7/16"	\$117
FIPMT.1648	16"	48"	7/16"	\$130

24"H

PART #	HEIGHT	WIDTH	DEPTH	PRICE
FIPMT.2424	24"	24"	7/16"	\$110
FIPMT.2430	24"	30"	7/16"	\$129
FIPMT.2436	24"	36"	7/16"	\$149
FIPMT.2442	24"	42"	7/16"	\$168
FIPMT.2448	24"	48"	7/16"	\$187

Laminate Tile (NEW)

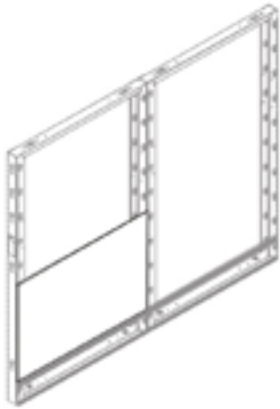

DESCRIPTION

Laminate tile attaches to one side of a frame of the same width.

SPECIFICATION OPTIONS

product #: see charts below
laminate: see page 9
finish: CW, BU, or SV

NOTES

- Laminate tiles cannot be installed on stacking frames or wall strips
- Laminate tiles cannot be installed at the beltline (29" - 37" above the floor).
- **Exception:** 45"H frames - laminate tiles can be installed at the top of 45"H frames.
- Application is the same as markerboard
See Interra Pricebook for details
- Grain direction is vertical

ORDER EXAMPLE

product #: FILT.1624
laminate: 7937-60 River Cherry
finish: BU Black Umber

16" HIGH

PART #	HEIGHT	WIDTH	LIST
FILT.1624	16"	24"	\$311
FILT.1630	16"	30"	\$343
FILT.1636	16"	36"	\$405
FILT.1642	16"	42"	\$422
FILT.1648	16"	48"	\$439

32" HIGH

PART #	HEIGHT	WIDTH	LIST
FILT.3224	32"	24"	\$458
FILT.3230	32"	30"	\$515
FILT.3236	32"	36"	\$655
FILT.3242	32"	42"	\$660
FILT.3248	32"	48"	\$687

Frameless Glass | Clear

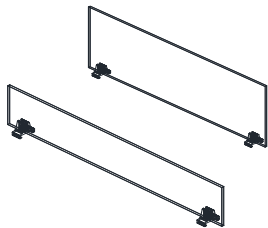

DESCRIPTION

Frameless glass mounted to Interra panel top cap

SPECIFICATION OPTIONS

product #: see charts below

NOTES

- Frameless Glass screens are attached to the top of a single frame with included hardware.
- Matches the width of the frame.
- 3/4" gap between glass in a straight line
- 5/16" gap at change of height bracket
- Frameless glass will not fit between two taller panels at change of height. Frameless glass is narrow enough to accommodate adjacent change of height trim on one side, but not both.

ORDER EXAMPLE

product #: FIFG.0824-CL

FRAMELESS GLASS 8" CLEAR

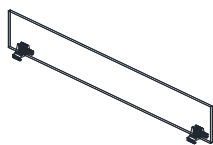

PART #	HEIGHT	WIDTH	DEPTH	PRICE	NOTES
FIFG.0824-CL	8"	23-1/4"	—	\$324	Includes attachment hardware, brushed finish.
FIFG.0830-CL	8"	29-1/4"	—	\$353	
FIFG.0836-CL	8"	35-1/4"	—	\$379	Package contains 2 pieces of glass and 4 brackets.
FIFG.0842-CL	8"	41-1/4"	—	\$408	
FIFG.0848-CL	8"	47-1/4"	—	\$435	

FRAMELESS GLASS 14" CLEAR

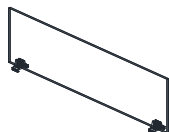

PART #	HEIGHT	WIDTH	DEPTH	PRICE	NOTES
FIFG.1424-CL	14"	23-1/4"	—	\$411	Includes attachment hardware, brushed finish.
FIFG.1430-CL	14"	29-1/4"	—	\$456	
FIFG.1436-CL	14"	35-1/4"	—	\$500	Package contains 2 pieces of glass and 4 brackets.
FIFG.1442-CL	14"	41-1/4"	—	\$543	
FIFG.1448-CL	14"	47-1/4"	—	\$594	

Frameless Glass | Frosted

FRAMELESS GLASS 8" FROSTED

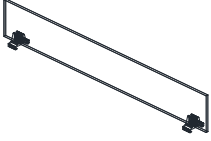

PART #	HEIGHT	WIDTH	DEPTH	PRICE
FIFG.0824-FR	8"	23-1/4"	—	\$420
FIFG.0830-FR	8"	29-1/4"	—	\$471
FIFG.0836-FR	8"	35-1/4"	—	\$524
FIFG.0842-FR	8"	41-1/4"	—	\$575
FIFG.0848-FR	8"	47-1/4"	—	\$628

NOTES

Includes attachment hardware, brushed finish.

Package contains 2 pieces of glass and 4 brackets.

FRAMELESS GLASS 14" FROSTED



PART #	HEIGHT	WIDTH	DEPTH	PRICE
FIFG.1424-FR	14"	23-1/4"	—	\$575
FIFG.1430-FR	14"	29-1/4"	—	\$664
FIFG.1436-FR	14"	35-1/4"	—	\$753
FIFG.1442-FR	14"	41-1/4"	—	\$840
FIFG.1448-FR	14"	47-1/4"	—	\$932

NOTES

Includes attachment hardware, brushed finish.

Package contains 2 pieces of glass and 4 brackets.

FRAMELESS GLASS SLIM BRACKET

PART #	HEIGHT	WIDTH	DEPTH	PRICE
FIFGB-SL	—	—	—	\$54

NOTES

Sold as single bracket.

Slim bracket is used in place of an existing bracket in configurations where an overhead storage is adjacent to the frameless glass.

Top Cap | with Glass

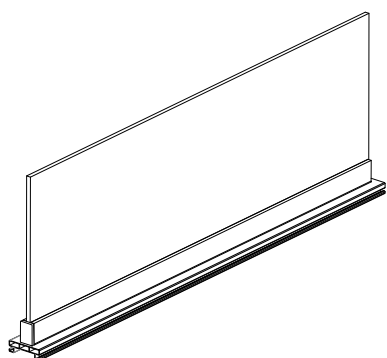

DESCRIPTION

Top cap with glass attaches to the top of Interra frames. Glass is available in clear and frosted styles.

NOTES

- Product includes (1) Top Cap and (1) piece of glass.
- Attaches to the top of Interra frames
- Available in 8" and 14" heights
- Choice of clear or frosted glass
- Specify Top Cap finish
- Frameless glass will not fit between two taller panels at change of height. Frameless glass is narrow enough to accommodate adjacent change of height trim on one side, but not both.
- Sold each

SPECIFICATION OPTIONS

product #: see charts below
top cap finish: CW, BU, SV

ORDER EXAMPLE

product #: FIGTC.0824-CL
top cap finish: CW

8"H, CLEAR

PART #	HEIGHT	WIDTH	DEPTH	PRICE
FIGTC.0824-CL	8"	24"	—	\$184
FIGTC.0830-CL	8"	30"	—	\$215
FIGTC.0836-CL	8"	36"	—	\$247
FIGTC.0842-CL	8"	42"	—	\$279
FIGTC.0848-CL	8"	48"	—	\$312
FIGTC.0854-CL	8"	54"	—	\$371
FIGTC.0860-CL	8"	60"	—	\$416
FIGTC.0866-CL	8"	66"	—	\$460
FIGTC.0872-CL	8"	72"	—	\$507

NOTES

- Product includes (1) Top Cap and (1) piece of glass
- Attaches to the top of Interra frames
- 8" high Top Cap with clear glass
- Specify Top Cap finish

8"H, FROSTED

PART #	HEIGHT	WIDTH	DEPTH	PRICE
FIGTC.0824-FR	8"	24"	—	\$246
FIGTC.0830-FR	8"	30"	—	\$293
FIGTC.0836-FR	8"	36"	—	\$340
FIGTC.0842-FR	8"	42"	—	\$389
FIGTC.0848-FR	8"	48"	—	\$437
FIGTC.0854-FR	8"	54"	—	\$487
FIGTC.0860-FR	8"	60"	—	\$530
FIGTC.0866-FR	8"	66"	—	\$572
FIGTC.0872-FR	8"	72"	—	\$618

NOTES

- Product includes (1) Top Cap and (1) piece of glass
- Attaches to the top of Interra frames
- 8" high Top Cap with frosted glass
- Specify Top Cap finish

14"H, CLEAR

PART #	HEIGHT	WIDTH	DEPTH	PRICE
FIGTC.1424-CL	14"	24"	—	\$223
FIGTC.1430-CL	14"	30"	—	\$263
FIGTC.1436-CL	14"	36"	—	\$302
FIGTC.1442-CL	14"	42"	—	\$341
FIGTC.1448-CL	14"	48"	—	\$383
FIGTC.1454-CL	14"	54"	—	\$450
FIGTC.1460-CL	14"	60"	—	\$503
FIGTC.1466-CL	14"	66"	—	\$553
FIGTC.1472-CL	14"	72"	—	\$608

NOTES

-
- Product includes (1) Top Cap and (1) piece of glass
 - Attaches to the top of Interra frames
 - 14" high Top Cap with clear glass
 - Specify Top Cap finish

14"H, FROSTED

PART #	HEIGHT	WIDTH	DEPTH	PRICE
FIGTC.1424-FR	14"	24"	—	\$331
FIGTC.1430-FR	14"	30"	—	\$398
FIGTC.1436-FR	14"	36"	—	\$466
FIGTC.1442-FR	14"	42"	—	\$532
FIGTC.1448-FR	14"	48"	—	\$603
FIGTC.1454-FR	14"	54"	—	\$654
FIGTC.1460-FR	14"	60"	—	\$729
FIGTC.1466-FR	14"	66"	—	\$803
FIGTC.1472-FR	14"	72"	—	\$880

NOTES

-
- Product includes (1) Top Cap and (1) piece of glass
 - Attaches to the top of Interra frames
 - 14" high Top Cap with frosted glass
 - Specify Top Cap finish

Panel Mounted Acrylic Screen (NEW)

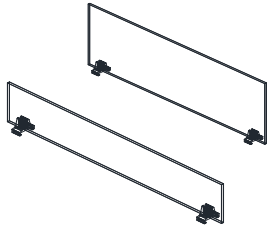

DESCRIPTION

Acrylic screen that attach to the top of a single frame

SPECIFICATION OPTIONS

product #: see charts below

NOTES

- Hardware included
- Clear acrylic screen, 8mm thick
- Actual screen size is less 1/2" high and 1/8" wide
- Screen will NOT fit at change of height location. Screen width will not accomodate the depth needed for change of height trim
- Sold each

ORDER EXAMPLE

product #: FIPLSC.1424-CL

14" H CLEAR

PART #	HEIGHT	WIDTH	LIST
FIPLSC.1424-CL	14"	24"	\$399
FIPLSC.1430-CL	14"	30"	\$422
FIPLSC.1436-CL	14"	36"	\$444
FIPLSC.1442-CL	14"	42"	\$467
FIPLSC.1448-CL	14"	48"	\$489

16" H CLEAR

PART #	HEIGHT	WIDTH	LIST
FIPLSC.1624-CL	16"	24"	\$412
FIPLSC.1630-CL	16"	30"	\$438
FIPLSC.1636-CL	16"	36"	\$464
FIPLSC.1642-CL	16"	42"	\$489
FIPLSC.1648-CL	16"	48"	\$515

18" H CLEAR

PART #	HEIGHT	WIDTH	LIST
FIPLSC.1824-CL	18"	24"	\$425
FIPLSC.1830-CL	18"	30"	\$454
FIPLSC.1836-CL	18"	36"	\$483
FIPLSC.1842-CL	18"	42"	\$512
FIPLSC.1848-CL	18"	48"	\$541

24" H CLEAR

PART #	HEIGHT	WIDTH	LIST
FIPLSC.2424-CL	24"	24"	\$464
FIPLSC.2430-CL	24"	30"	\$502
FIPLSC.2436-CL	24"	36"	\$541
FIPLSC.2442-CL	24"	42"	\$579
FIPLSC.2448-CL	24"	48"	\$618

For use with
SYSTEM 2

Frameless Glass

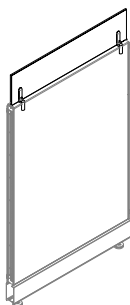

DESCRIPTION

Glass screen mounts to System 2 or Novo panel

NOTES

- Frameless Glass screens are attached to the top of a single frame with included hardware.
- Matches width of the frame.
- Package contains 2.
- Frameless glass will not fit between two taller panels at change of height. Frameless glass is narrow enough to accommodate adjacent change of height trim on one side, but not both.

SPECIFICATION OPTIONS

product #: see charts below

ORDER EXAMPLE

product #: F2FG.0824-CL

FRAMELESS GLASS 8" CLEAR

PART #	HEIGHT	WIDTH	DEPTH	WT. (LBS)	PRICE
F2FG.0824-CL	8"	23-1/4"	—	—	\$349
F2FG.0830-CL	8"	29-1/4"	—	—	\$377
F2FG.0836-CL	8"	35-1/4"	—	—	\$403
F2FG.0842-CL	8"	41-1/4"	—	—	\$431
F2FG.0848-CL	8"	47-1/4"	—	—	\$459
F2FG.0860-CL	8"	59-1/4"	—	—	\$515

NOTES

- Includes attachment hardware, brushed finish.
- Package contains 2 pieces of glass and 4 brackets..

FRAMELESS GLASS 14" CLEAR

PART #	HEIGHT	WIDTH	DEPTH	WT. (LBS)	PRICE
F2FG.1424-CL	14"	23-1/4"	—	—	\$431
F2FG.1430-CL	14"	29-1/4"	—	—	\$478
F2FG.1436-CL	14"	35-1/4"	—	—	\$523
F2FG.1442-CL	14"	41-1/4"	—	—	\$568
F2FG.1448-CL	14"	47-1/4"	—	—	\$617
F2FG.1460-CL	14"	59-1/4"	—	—	\$711

NOTES

- Includes attachment hardware, brushed finish.
- Package contains 2 pieces of glass and 4 brackets..

FRAMELESS GLASS 8" FROSTED

PART #	HEIGHT	WIDTH	DEPTH	WT. (LBS)	PRICE
F2FG.0824-FR	8"	23-1/4"	—	—	\$401
F2FG.0830-FR	8"	29-1/4"	—	—	\$454
F2FG.0836-FR	8"	35-1/4"	—	—	\$506
F2FG.0842-FR	8"	41-1/4"	—	—	\$559
F2FG.0848-FR	8"	47-1/4"	—	—	\$611
F2FG.0860-FR	8"	59-1/4"	—	—	\$717

NOTES

- Includes attachment hardware, brushed finish.
- Package contains 2 pieces of glass and 4 brackets..

FRAMELESS GLASS 14" FROSTED

PART #	HEIGHT	WIDTH	DEPTH	WT. (LBS)	PRICE
F2FG.1424-FR	14"	23-1/4"	—	—	\$559
F2FG.1430-FR	14"	29-1/4"	—	—	\$647
F2FG.1436-FR	14"	35-1/4"	—	—	\$735
F2FG.1442-FR	14"	41-1/4"	—	—	\$821
F2FG.1448-FR	14"	47-1/4"	—	—	\$915
F2FG.1460-FR	14"	59-1/4"	—	—	\$1,091

NOTES

- Includes attachment hardware, brushed finish.
- Package contains 2 pieces of glass and 4 brackets..

Panel Mounted Acrylic Screen (NEW)

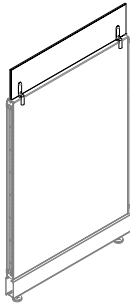

DESCRIPTION

Acrylic screen that attach to the top of a single frame

SPECIFICATION OPTIONS

product #: see charts below

NOTES

- Hardware included
- Clear acrylic screen, 8mm thick
- Actual screen size is less 1/2" high and 1/8" wide
- Screen will NOT fit at change of height location. Screen width will not accommodate the depth needed for change of height trim
- Sold each

ORDER EXAMPLE

product #: F2PLSC.1448-CL

14" H CLEAR

PART #	HEIGHT	WIDTH	LIST
F2PLSC.1424-CL	14"	24"	\$390
F2PLSC.1430-CL	14"	30"	\$413
F2PLSC.1436-CL	14"	36"	\$435
F2PLSC.1442-CL	14"	42"	\$458
F2PLSC.1448-CL	14"	48"	\$480
F2PLSC.1460-CL	14"	60"	\$525

16" H CLEAR

PART #	HEIGHT	WIDTH	LIST
F2PLSC.1624-CL	16"	24"	\$403
F2PLSC.1630-CL	16"	30"	\$429
F2PLSC.1636-CL	16"	36"	\$455
F2PLSC.1642-CL	16"	42"	\$480
F2PLSC.1648-CL	16"	48"	\$506
F2PLSC.1660-CL	16"	60"	\$558

18" H CLEAR

PART #	HEIGHT	WIDTH	LIST
F2PLSC.1824-CL	18"	24"	\$416
F2PLSC.1830-CL	18"	30"	\$445
F2PLSC.1836-CL	18"	36"	\$474
F2PLSC.1842-CL	18"	42"	\$503
F2PLSC.1848-CL	18"	48"	\$532
F2PLSC.1860-CL	18"	60"	\$590

24" H CLEAR

PART #	HEIGHT	WIDTH	LIST
F2PLSC.2424-CL	24"	24"	\$455
F2PLSC.2430-CL	24"	30"	\$493
F2PLSC.2436-CL	24"	36"	\$532
F2PLSC.2442-CL	24"	42"	\$570
F2PLSC.2448-CL	24"	48"	\$609
F2PLSC.2460-CL	24"	60"	\$686

For use with
NOVO

Frameless Glass Clear

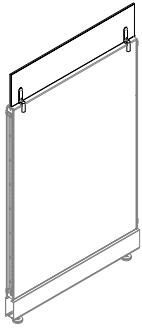

DESCRIPTION

Glass screen mounts to System 2 or Novo panel

SPECIFICATION OPTIONS

product #: see charts below

NOTES

- Frameless Glass screens are attached to the top of a single frame with included hardware.
- Matches width of the frame.
- Package contains 2.
- Frameless glass will not fit between two taller panels at change of height. Frameless glass is narrow enough to accommodate adjacent change of height trim on one side, but not both.

ORDER EXAMPLE

product #: F2FG.0824-CL

FRAMELESS GLASS 8" CLEAR

PART #	HEIGHT	WIDTH	DEPTH	WT. (LBS)	LIST	NOTES
F2FG.0824-CL	8"	23-1/4"	—	—	\$349	Includes attachment hardware, brushed finish.
F2FG.0830-CL	8"	29-1/4"	—	—	\$377	
F2FG.0836-CL	8"	35-1/4"	—	—	\$403	Package contains 2 pieces of glass and 4 brackets.
F2FG.0842-CL	8"	41-1/4"	—	—	\$431	
F2FG.0848-CL	8"	47-1/4"	—	—	\$459	

FRAMELESS GLASS 14" CLEAR

PART #	HEIGHT	WIDTH	DEPTH	WT. (LBS)	LIST	NOTES
F2FG.1424-CL	14"	23-1/4"	—	—	\$431	Includes attachment hardware, brushed finish.
F2FG.1430-CL	14"	29-1/4"	—	—	\$478	
F2FG.1436-CL	14"	35-1/4"	—	—	\$523	Package contains 2 pieces of glass and 4 brackets.
F2FG.1442-CL	14"	41-1/4"	—	—	\$568	
F2FG.1448-CL	14"	47-1/4"	—	—	\$617	

Frameless Glass Frosted

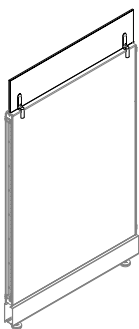

DESCRIPTION

Glass screen mounts to System 2 or Novo panel

SPECIFICATION OPTIONS

product #: see charts below

NOTES

- Frameless Glass screens are attached to the top of a single frame with included hardware.
- Matches width of the frame.
- Package contains 2.
- Frameless glass will not fit between two taller panels at change of height. Frameless glass is narrow enough to accommodate adjacent change of height trim on one side, but not both.

ORDER EXAMPLE

product #: F2FG.0824-FR

FRAMELESS GLASS 8" FROSTED

PART #	HEIGHT	WIDTH	DEPTH	WT. (LBS)	LIST	NOTES
F2FG.0824-FR	8"	23-1/4"	—	—	\$401	Includes attachment hardware, brushed finish.
F2FG.0830-FR	8"	29-1/4"	—	—	\$454	
F2FG.0836-FR	8"	35-1/4"	—	—	\$506	Package contains 2 pieces of glass and 4 brackets.
F2FG.0842-FR	8"	41-1/4"	—	—	\$559	
F2FG.0848-FR	8"	47-1/4"	—	—	\$611	

FRAMELESS GLASS 14" FROSTED

PART #	HEIGHT	WIDTH	DEPTH	WT. (LBS)	LIST	NOTES
F2FG.1424-FR	14"	23-1/4"	—	—	\$559	Includes attachment hardware, brushed finish.
F2FG.1430-FR	14"	29-1/4"	—	—	\$647	
F2FG.1436-FR	14"	35-1/4"	—	—	\$735	Package contains 2 pieces of glass and 4 brackets.
F2FG.1442-FR	14"	41-1/4"	—	—	\$821	
F2FG.1448-FR	14"	47-1/4"	—	—	\$915	

Panel Mounted Acrylic Screen (NEW)

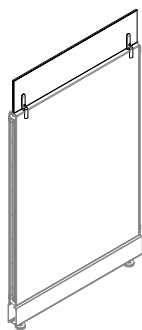

DESCRIPTION

Acrylic screen that attach to the top of a single panel

SPECIFICATION OPTIONS

product #: see charts below

NOTES

- Hardware included
- Clear acrylic screen, 8mm thick
- Actual screen size is less 1/2" high and 1/8" wide
- Screen will NOT fit at change of height location. Screen width will not accommodate the depth needed for change of height trim
- Sold each

ORDER EXAMPLE

product #: F2PLSC.1448-CL

14" H CLEAR

PART #	HEIGHT	WIDTH	LIST
F2PLSC.1424-CL	14"	24"	\$390
F2PLSC.1430-CL	14"	30"	\$413
F2PLSC.1436-CL	14"	36"	\$435
F2PLSC.1442-CL	14"	42"	\$458
F2PLSC.1448-CL	14"	48"	\$480

16" H CLEAR

PART #	HEIGHT	WIDTH	LIST
F2PLSC.1624-CL	16"	24"	\$403
F2PLSC.1630-CL	16"	30"	\$429
F2PLSC.1636-CL	16"	36"	\$455
F2PLSC.1642-CL	16"	42"	\$480
F2PLSC.1648-CL	16"	48"	\$506

18" H CLEAR

PART #	HEIGHT	WIDTH	LIST
F2PLSC.1824-CL	18"	24"	\$416
F2PLSC.1830-CL	18"	30"	\$445
F2PLSC.1836-CL	18"	36"	\$474
F2PLSC.1842-CL	18"	42"	\$503
F2PLSC.1848-CL	18"	48"	\$532

24" H CLEAR

PART #	HEIGHT	WIDTH	LIST
F2PLSC.2424-CL	24"	24"	\$455
F2PLSC.2430-CL	24"	30"	\$493
F2PLSC.2436-CL	24"	36"	\$532
F2PLSC.2442-CL	24"	42"	\$570
F2PLSC.2448-CL	24"	48"	\$609

FRÍANT

Shield Screens and Panels

Products that address the return to the office.