

# **FRÍANT**

## **Shield Screens and Panels**

Products that address the return to the office.

## TABLE OF CONTENTS

---

### INTRODUCTION

Terms and Conditions	3
Care and Maintenance	6
Standard Fabrics	7
Pattern Direction	8
Standard Finishes	9

### APPLICATION GUIDE

Verity	12
My-Hite	14
Interra	15
System 2	15
Novo	16

### SHIELD PRODUCTS

Freestanding Laminate Panel Feet	18
Freestanding Laminate Panel Casters	19
Freestanding Markerboard Panel Feet	20
Freestanding Markerboard Panel Casters	21
Shield Acrylic Freestanding Screen	22
Shield Acrylic Clamp Screen	24
Shield Acrylic Panel-Mounted Screen	25

### MY-HITE/UNIVERSAL

#### PRIVACY SCREENS

Worksurface mounted	
Acrylic screen (NEW)	27
Worksurface mounted	
Fabric covered screens (NEW)	29
Worksurface mounted glass screens	30
Privacy Screen, Fabric	32
Privacy Screen, Marker Board	33
Privacy Screen, Laminate	34
Flyp Screens	35

### VERITY

#### SUPPORTING STORAGE

Cabinets	37
----------	----

#### STORAGE

Over-Worksurface Storage	
Single-Sided	38
Double-Sided	40

### TRACK-MOUNTED ACCESSORIES

Fabric Screen	42
Glass Screen	43
Acrylic Screen (NEW)	44

### WORKSURFACE-MOUNTED ACCESSORIES

Acrylic Screen (NEW)	45
Fabric Tackboard	46
Glass Screen	47
Markerboard Screen	47

### INTERRA

#### FRAMES

Stacking Frames	49
-----------------	----

#### TILES

Perforated Metal Tile	50
Laminate Tile (NEW)	51

#### SCREENS

Frameless Glass	52
Top Cap with Glass	54
Panel Mounted Acrylic Screen (NEW)	56

### SYSTEM 2

#### SCREENS

Frameless Glass	58
Panel Mounted Acrylic Screen (NEW)	59

### NOVO

#### SCREENS

Frameless Glass	61
Panel Mounted Acrylic Screen (NEW)	63

## Terms and Conditions

---

### PRICES

Pricing is delivered, freight included to 48 contiguous states. Specific requirements apply, minimum order required, see freight policy for details. See complete freight rules and policy on [www.friant.com](http://www.friant.com).

### ORDERING

Purchase Orders should be sent to [orders@friant.com](mailto:orders@friant.com) or faxed to (510) 535-6895. If your specifications were created with CAP, GIZA or Project Matrix, please send the worksheet (.SP4, or .SIF) with your Purchase Order.

### TERMS

Net 30 days from date of invoice. Invoices are delinquent if not paid 30 days from date of invoice. In the event timely payment is not made, interest will be charged at the rate of 1.5% per month on delinquent accounts. Buyers will also be liable for normal collection costs and attorney's fee. 50% deposit is required with every order, unless prior arrangements have been made.

### ORDERS

Orders are only accepted by issuance of our formal acknowledgment, and are subject to the terms set forth herein and on our order acknowledgment. It is the responsibility of the buyer to review our acknowledgment for accuracy.

### LEAD TIME

Lead times are subject to availability, see [www.Friant.com](http://www.Friant.com) for details.

### SHIPPING

Friant generally palletizes, boxes and/or shrink-wraps its products. If buyer requests additional packaging or special shipping, then it is responsible for any extra costs that result. Buyer obtains title to products and assumes the risk of loss for them upon shipment from Friant's plant.

### CLAIMS

We are not responsible for damage suffered in transit. Merchandise should be inspected for possible freight damage upon delivery. The consignee should file for damage or shortages with the carrier within 5 days of delivery. You are also protected for "concealed damage" if you file claim with the carrier within 5 days of delivery. Buyer must make all claims against Friant for defects, errors or shortages in writing within 10 days after delivery. Failure to make such a claim shall constitute full acceptance.

### RETURNS

No merchandise may be returned without our written consent and shipping instructions. Unauthorized returns will not be accepted and will be returned freight collect.

### PARTIAL SHIPMENTS

We will make every attempt to ship orders complete and on schedule. However, we reserve the right to make partial shipments, as merchandise is ready. Invoices covering these shipments are to be paid as they become due.

### ORDER CHANGE/CANCELLATIONS

Our order confirmation is final and binding. Product is made to order, no returns or cancellations are permitted. For the most up to date information, always review the order change/cancellation policy online.

### SHIPMENT AND PREPAID FREIGHT

Unless otherwise instructed, we reserve the option to ship by what is, in our opinion, the best possible way. Upon request, we will prepay and add freight for accounts with established credit.

### DELIVERY

We are not liable for delay or failure of delivery due to strikes and/or differences with workmen, war, riot, fire, compliance with government regulations, acts of nature, failure or delays of sources of supply, or any other causes beyond our control.

### STORAGE

If buyer cannot accept delivery when merchandise is ready, we reserve the right to transfer goods to storage. Costs of transfer and storage will be charged to the buyer's account, and we will deem such transfer as constituting shipment for all purposes, including invoicing, as of the date the transfer is made.

## Terms and Conditions

---

### CONSTRUCTION — SPECIFICATIONS

All items are produced to price list specifications unless otherwise advised. All dimensions shown are approximate. Manufacturer reserves the right to make modifications and/or improvements without prior notice.

### FABRIC APPLICATION

Standard fabric application is non-directional. Friant & Associates is not responsible for charges associated with replacement of products due to incorrect specifications. Certain product construction and sizes require fabric to be applied only Directionally or Non-Directionally. See individual pricebook specifications for details.

### CUSTOMER'S OWN MATERIAL

Yardage requirement is based on 66" wide plain covering material, and must be increased if less than 66" wide. Special instructions for handling material (pattern, directional fabric, right side of reversible fabric, etc.) must be submitted in writing before fabric is delivered. In the absence of special instructions, we reserve the right to use our own judgment. We reserve the right to reject any covering, which in our opinion, is unsuitable for our upholstery purposes. However, in no instance shall we be held responsible for unsatisfactory results due to use of covering unsuitable for our upholstery methods.

We will not be responsible for errors caused by buyers not supplying us with sample cuttings attached to their order giving full identification of covering material, (name of supplier, covering name, number and color) for identification purposes and advising us of model number and quantity to which each cover is to be applied.

Customer's own material that is shipped freight collect will be refused. A service charge will be applied for the return of unusable C.O.M. Contact factory.

### RIGHTS AND WARRANTIES — LIMITED LIFETIME

This warranty is given to the initial purchaser and is valid from the date of purchase, for as long as the initial purchaser owns the product. This warranty covers defects in material and craftsmanship found during normal usage of the product during the warranty period. Normal usage is defined by 8 hour shifts in the product's intended application and in an indoor environment that conforms to the ANSI/ASHRAE Standard 55: Thermal Environmental Conditions for Human Occupancy (relating to air temperature, mean radiant temperature, air velocity, clothing insulation, metabolic rate, and humidity). Friant's warranty does not cover usage other than normal usage as defined in the previous sentence. If the product is defective, and if written notice of the defect is given to Friant & Associates within the applicable warranty period, Friant & Associates, at its option, will either repair or replace the defective product with a comparable component or product. This warranty applies to all products except as noted below.

High wear parts, such as wood veneer, fabrics, laminates, acrylic, and other covering material/finishes, foam, glides, etc. are warranted for one (1) year. This warranty does not apply to damage caused by a carrier, alteration to the product not expressly authorized by Friant & Associates, nor to product considered to be of a consumable nature such as bulbs, light ballasts, etc. It also does not apply to "Customer's Own Material" (i.e. material specified by the customer that is not a standard Friant & Associates offering) used in the manufacture of Friant & Associates products.

Many Shield products are offered with flexible mounting options that can be utilized in many different applications and paired with many different furniture solutions. It is the sole responsibility of the ordering dealer to identify the proper application, order appropriate hardware and ensure all Shield products are securely and safely installed. Shield products have not been certified by a 3rd party laboratory to meet or exceed ANSI/BIFMA standards.

Product is made to order, no returns or cancellations.

Our warranty for LED lights is 2 years.

Friant & Associates does not warrant the matching of colors, grain or texture, except to within commercially acceptable standards. This includes normal variations between dye lots (fabrics).

A product will not be considered defective, and Friant & Associates will not be obligated to replace it, if it is not installed in a proper manner (i.e. product not leveled, not secured properly, etc.) or if it is not used in a manner and/or in an environment that constitutes normal usage, as defined above.

Except as noted above, Friant & Associates makes no express or implied warranties to any product, and in particular makes no warranty of fitness for any particular use. At Friant & Associates' option, product repair and replacement is the customer's exclusive remedy for any and all product defects.

Friant & Associates shall not be liable for consequential, economic, or incidental damages arising from any product defect.

## Terms and Conditions

---

### **CALIFORNIA PROP 65 WARNING**

Products in this catalog can expose you to chemicals including wood dust, which is known to the State of California to cause cancer or birth defects or other reproductive harm. For more information go to <https://www.p65warnings.ca.gov/products/furniture-products>.”

### **CARB**

Friant products are CARB 93120 compliant for formaldehyde (phase 2)

### **TSCA TITLE VI**

Friant products are TSCA Title VI Compliant

### **MAS**

Accredited Compliance Designation - ANSI/BIFMA x7.1 & e3-2014 7.6.1, 7.6.2, 7.6.3

California Dept. Of Public Health Standard Method v1.2

Conforms With: LEED v4

Criteria of MAS Certified Green ® Program

## Finish Care & Maintenance Guide

With regular care and maintenance, your Friant furniture will provide years of superior performance and satisfaction. To maintain the finish quality of your Friant products, please follow the cleaning procedures provided below. The instruction for the care and maintenance of Friant products are provided to you as a service. No warranty is implied, since we cannot monitor the methods and materials used for maintenance.

### COATED METAL

For normal cleaning, wipe coated metal surfaces with a soft cloth, soaked in detergent and warm water; rinse thoroughly and dry. Remove scuff marks from low-gloss coatings with pre-softened paste wax, following the manufacturer's instructions.

Remove scuff marks and scratches from high-gloss coatings using automotive polishing compounds, either liquid or paste. After polishing, apply a pre-softened automotive paste wax to restore original sheen.

### POLISHED ALUMINUM

For normal cleaning, apply a pre-softened paste wax to polished aluminum components following the manufacturer's instructions. In humid atmospheres near salt water, apply the wax once a month. In other areas, apply wax every three months to maintain the appearance of the aluminum.

### POLISHED CHROME

For normal cleaning, wet cheesecloth in a nonabrasive cleaner, like liquid dish soap, and rub the chrome component lightly until the original luster reappears. Dry the component with a soft cloth to remove any soap residue.

### SEATING/ PANEL FABRICS

The following are general recommendations to maintain the good condition of your panel fabric:

- Vacuum the fabric periodically to remove accumulated dirt and dust. The required frequency of this and any other routine maintenance is determined by end use conditions.
- Blot fresh spills immediately.
- Ensure that the fabric is adequately rinsed after cleaning, as residual cleaning agents may accelerate soiling.
- Have the fabric professionally cleaned whenever large stains or an overall soiled conditions occurs.

For most water-based stains, a clean, absorbent cloth dampened with a detergent solution (e.g. 1 teaspoon laundry detergent/1 pint warm water) should be applied to the stain. Blot the fabric with the treated cloth, working from the outer edge of the stained area, moving inward. In order to effectively draw out the stain, renew the cleaning cloth frequently. Rinse well with clear water, and dry the fabric as quickly as practical. Oil-based stains may be treated in manufacturer's recommendations for using such products, and always pretest an inconspicuous area of the fabric for colorfastness to the cleaning agent.

For stains that do not respond to these basic methods, please contact a professional upholstery cleaner.

### LAMINATES

For normal cleaning, wipe the laminate with a soft cloth and a solution of mild detergent and warm water. Rinse thoroughly and dry with a soft cloth.

For minor repair of stubborn marks, apply a nonabrasive liquid kitchen cleanser with a soft cloth soaked in warm water. Rub in the direction of the grain; use caution to avoid damaging the surface texture or gloss. If no grain direction is visible, rub with a light, circular motion.

You can use acetone, alcohol, Windex, or a typical non-abrasive house hold cleaner including a bleach water solution. Do not use powdered abrasives or other harsh cleansers like hypochlorite bleach, hydrogen peroxide, nitric or hydrochloric acids or lye; they may deface the surface and change the finish color.

### WOOD & VENEER

For normal cleaning, dust furniture daily with a slightly damp, soft, lint-free cloth. Wipe dry with a dry, soft cloth in the direction of the wood grain.

Once a month, clean the surface with a soft cloth dampened with a quality cleaner formulated for wood furniture. Wipe the surface in the direction of the wood grain to remove dirt and fingerprints. Wipe dry with a clean, dry cloth.

Twice a year, apply a good quality emulsion wax with a soft cloth. Emulsion wax is clear and prevents fingerprints. Do not use aerosol-powered cleaners, polishes, waxes, abrasive cleaners, or oily polishes.

For minor repair of water rings, stains and scratches, rub the surface lightly in the direction of the wood grain using No. 000 steel wool. Apply a scratch-removing polish with a color and value that simulate the veneer. If the scratches are deep, consult a professional furniture refinisher.

### GLASS

Use cleaning products specifically designed for glass.

### ACRYLIC

Start by looking at how dirty the surface is. This will help you determine how strong of a cleaning solution you need to use. In some cases you might want to use a spray bottle or soak the surfaces if possible. For daily cleaning wipe acrylic surfaces with a soft cloth soaked in mild dish soap and warm water. Rinse thoroughly and dry with a soft cloth. Do not use solvents or abrasive kitchen cleaners.

### CHAIR BASES

For normal cleaning, wipe bases with warm, soapy water. Rinse and wipe dry with a soft cloth. Do not use any solvents or abrasive materials.

## Standard Fabrics

JOURNEY		SLIDE		SILKY		SKY	
PF801-1	Quest	PF101-1	Caramel	PF401-1	Natural	PF301-1	Terra
PF801-2	Voyage	PF101-2	Slate	PF401-2	Parids	PF301-2	Birch
PF801-3	Transit	PF101-3	Pewter	PF401-3	Overcast	PF301-3	Moss
PF801-4	Amble	PF101-7	Java	PF401-5	Graphite		
PF801-5	Odyssey	PF101-9	Sterling				
PF801-6	Caravan	PF101-10	Crema				
PF801-7	Expedition	PF101-13	Mustard				
PF801-8	Wayfare	PF101-14	Avocado				
		PF101-15	Pumpkin				
		PF101-16	Ocean				
		PF101-17	Blueberry				
		PF101-18	Cardinal				
		PF101-19	Flamingo				
		PF101-20	Serenity				
		PF101-21	Azure				
		PF101-22	Orchid				
		PF101-23	Plum				
		PF101-24	Raven				

### LIMITED AVAILABILITY

SLIDE		SILKY		STICKS	
PF101-4	Verde	PF401-4	Field	PF501-3	Sage
PF101-6	Vintage			PF501-4	Straw
PF101-8	Latte				
PF101-12	Stem				

**Fabric is scheduled for discontinuation when inventory is exhausted. Please contact Customer Service for current stock levels. After discontinuation fabric will be available with extended lead time, subject to minimum yardage requirements.**

### NOTES:

- Passage and Terrain are not available on acoustical panels, pedestal cushions, tackboards or fabric screens.
- Please refer to the Fabric Direction Section in the Materials Reference Guide on the Dealer Resource Center for more details: <http://dealers.friant.com/dealers/product-literature/>
- Order fabric / finish sample online at [www.friant.com](http://www.friant.com)
- Colors may vary slightly between dye lots.

## Pattern Direction

- Fabric direction is not always determined by the way the pattern is shown on memo sample.
- Certain product construction and sizes require fabric to be applied only Directionally or Non-Directionally.
- Some products have fabric applied either Directionally or Non-Directionally. (Upcharges may apply on some products, see price books for details).
- Please refer to our Materials Reference Guide on the Dealer Resource Center for specific pattern application defaults on all of our products : <http://dealers.friant.com/dealers/product-literature/>
- Our Customer Service Team is happy to answer any questions regarding fabric direction.

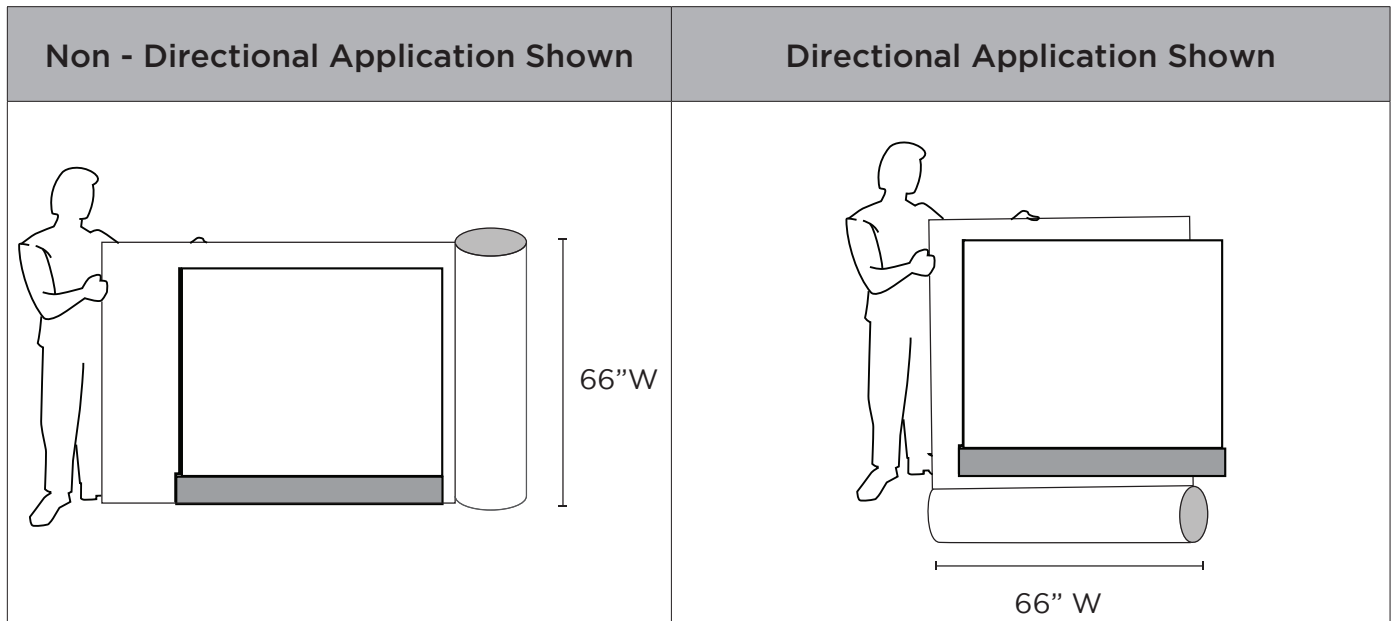



## Standard Finishes

Use the matrix below to identify surface and hardpanel finish options. Please note, M1-M13 offer close matching finishes, while M14-M29 are paired as color matched finishes.

Specify hardsurface panel finish for Interra laminate tiles

Specify surface finish on Shield panels and laminate privacy screens. For Shield panels, colors available are marked below

\* Shield Standard lead time

\*\* Shield Quickship

All other colors available on Shield panels through Customs

Order samples at  
[www.friant.com/samples](http://www.friant.com/samples)

**Please Note:** Images are printed simulations and are not exact matches of finished product. Please request an actual sample from Friant or your sales consultant before specifying finishes.

### PAINT TRIM

CW Cloud White

BU Black Umber

SV Silver

SURFACE FINISHES		HARDSURFACE PANEL FINISHES		SUPPLIER
M1	Light Maple*	7909-60	Fusion Maple	Wilsonart
M2	Light Cherry	7054-60	Wild Cherry	Wilsonart
M3	Medium Cherry	7924K-70	Biltmore Cherry	Wilsonart
M4	Dark Mahogany	7040K-78	Figured Mahogany	Wilsonart
M5	Light Mahogany	7039K-78	Windsor Mahogany	Wilsonart
M6	Light Gray	D327-60	Pepperdust	Wilsonart
M7	Off White	1572-60	Antique White	Wilsonart
M8	Gray Specks	4621-60	White Nebula	Wilsonart
M9	Cloud White**	1573-60	Frosty White	Wilsonart
M10	Espresso*	7933K-07	Cafelle	Wilsonart
M11	Light Walnut*	7937-60	River Cherry	Wilsonart
M12	Medium Walnut	7965K-12	Walnut Heights	Wilsonart
M13	Licorice	FB3920	Licorice Groovz	Arauco
M14	Carob	FB3560	Driftwood	Arauco
M15	Mousse	FB2960	Mochatini	Arauco
M16	Tundra	FB3930	Concrete Groovz	Arauco
M17	Cocoa	FB2990	Nirvana	Arauco
M18	Capitan	FB3400	Aria	Arauco
M19	Fog	FB2100	Silver Frost	Arauco
M20	Sandstone	FB2090	Shadow Frost	Arauco
M21	Medium Oak	FB2030	Seria	Arauco
M22	Harbor	FB4310	Umbr	Arauco
M23	Bark	FB3970	Stromboli	Arauco
M24	Tarmac	FB4320	Ashen	Arauco
M25	Winter	FB2130	Fog Grey	Arauco
M26	Storm	FB2000	Pewter Frost	Arauco
M27	Medium Ash	8842	Weathered Ash	Formica
M28	Arctic	8841	White Ash	Formica
M29	Raven	1595-60	Black	Wilsonart
		D91-60	Slate Gray	Wilsonart

Contact suppliers directly for hardsurface panel finish samples.

#### Wilsonart

tel: 800-433-3222, <https://www.wilsonart.com/contact-us>

#### Formica

tel: 800-367-6422, <https://www.formica.com/en-us/collections/commercial-ranges>

#### Arauco

Samples can be ordered at <https://store.samplingproduct.com/8340>.

## Special Materials

---

### **Antimicrobial Laminates**

Wilsonart HD laminates with built in antimicrobial protection

Available in 45 colors

<https://www.wilsonart.com/laminate/wilsonart-hd>

Available as a special material application. Submit Custom quote request through the Dealer Resource Center.

### **Bleach Cleanable Fabrics**

Guilford of Maine offers bleach-cleanable fabrics

<https://www.guilfordofmaine.com/>

Some have already been approved for COM application

Bailey

Beacon

Hatchet

Pursuit

Synopsis

These are available through the standard COM process. Please contact Customer Service for any questions about COM.

### **Antimicrobial Finish**

Guilford of Maine offers an antimicrobial finish that can be added to any of their patterns

<https://www.guilfordofmaine.com/>

A complete list of Guilford of Maine fabrics that have been approved for COM can be found in the Dealer Resource Center.



**SIMPLE DESIGNS | FAST TO INSTALL | EASY TO CLEAN**

## **SHIELD by Fríant**

**We have designed our new Shield Screens and Panels to provide solutions relevant for addressing “back to the office” solutions that help define space between employees and keep them feeling as comfortable as possible.**

# VERITY

- 1** Track Mounted Screens 42
- 2** Worksurface Mounted Screens 45
- 3** Freestanding Shield Panel 18



- 1** Track Mounted Screens 42
- 2** Worksurface Mounted Screens 45
- 3** Supporting Storage 37



- 1** Over worksurface Storage 38
- 2** Track Mounted Screens 42
- 3** Worksurface Mounted Screens 45



# VERITY

- 1 Track Mounted Screens 42
- 2 Shield Freestanding Screens 22



- 1 Worksurface Mounted Screens 45
- 2 Track Mounted Screens 42
- 3 Shield Mobile Panel 19



# MY-HITE

**1** Shield Freestanding Screens 22



# MY-HITE & BEAM

**1** Shield Clamp Screens 24



# INTERRA

- 1** Freestanding Shield Panels 18



# SYSTEM 2

- 1** Privacy Screens 32
- 2** Shield Panel-Mounted Screen 25



# NOVO

1 Shield Freestanding Panel

18



1 Shield Freestanding Screen

22







## SHIELD Freestanding Laminate Panel Feet

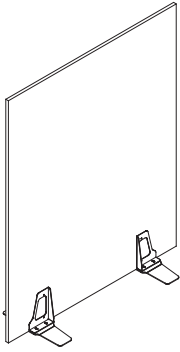

### DESCRIPTION

Freestanding laminate panel with feet.

### NOTES

- Dimensions are actual
- Laminate is 3/4" thick
- Laminate colors:
  - M1 Light Maple
  - M9 Cloud White\*
  - M10 Espresso
  - M11 Light Walnut
  - For all other laminate colors, please request a Custom quote
  - \*Quickship
- Painted metal feet in Cloud White

### SPECIFICATION OPTIONS

**product #:** see charts below  
**surface finish:** see notes below

### ORDER EXAMPLE

**product #:** FZFS.4853  
**surface finish:** M9 Cloud White

### 45" HIGH

PART #	HEIGHT	WIDTH	LIST
FZFS.3045	45"	30"	\$903
FZFS.3645	45"	36"	\$964
FZFS.4245	45"	42"	\$1,025
FZFS.4845	45"	48"	\$1,085

### 53" HIGH

PART #	HEIGHT	WIDTH	LIST
FZFS.3053	53"	30"	\$958
FZFS.3653	53"	36"	\$1,029
FZFS.4253	53"	42"	\$1,100
FZFS.4853	53"	48"	\$1,171

### 60" HIGH

PART #	HEIGHT	WIDTH	LIST
FZFS.3060	60"	30"	\$1,006
FZFS.3660	60"	36"	\$1,126
FZFS.4260	60"	42"	\$1,206
FZFS.4860	60"	48"	\$1,286

## SHIELD Freestanding Laminate Panel Casters

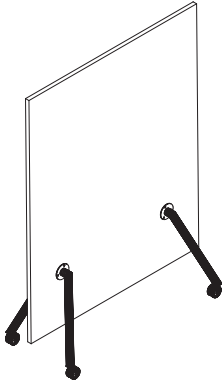

### DESCRIPTION

Freestanding laminate panel with casters.

### NOTES

- Dimensions are actual
- Laminate is 3/4" thick
- Laminate colors:
  - M1 Light Maple
  - M9 Cloud White\*
  - M10 Espresso
  - M11 Light Walnut
  - For all other laminate colors, please request a Custom quote
  - \*Quickship
- Legs are cloud white, casters are white
- Includes 4 locking casters

### SPECIFICATION OPTIONS

**product #:** see charts below  
**surface finish:** see notes below

### ORDER EXAMPLE

**product #:** FZFSMOB.4845  
**surface finish:** M9 Cloud White

#### 45" HIGH

PART #	HEIGHT	WIDTH	LIST
FZFSMOB.4245	45"	42"	\$1,161
FZFSMOB.4845	45"	48"	\$1,237

#### 53" HIGH

PART #	HEIGHT	WIDTH	LIST
FZFSMOB.4253	53"	42"	\$1,237
FZFSMOB.4853	53"	48"	\$1,307

#### 60" HIGH

PART #	HEIGHT	WIDTH	LIST
FZFSMOB.4260	60"	42"	\$1,303
FZFSMOB.4860	60"	48"	\$1,383

## SHIELD Freestanding Markerboard Panel Feet

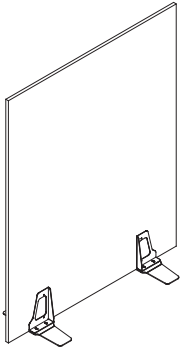

### DESCRIPTION

Freestanding markerboard panel with feet.

### NOTES

- Dimensions are actual
- Markerboard is 3/4" thick
- Painted metal feet in Cloud White

### SPECIFICATION OPTIONS

**product #:** see charts below

### ORDER EXAMPLE

**product #:** FZFMBS.4853

#### 45" HIGH

PART #	HEIGHT	WIDTH	LIST
FZFMBS.3045	45"	30"	\$1,425
FZFMBS.3645	45"	36"	\$1,589
FZFMBS.4245	45"	42"	\$1,755
FZFMBS.4845	45"	48"	\$1,919

#### 53" HIGH

PART #	HEIGHT	WIDTH	LIST
FZFMBS.3053	53"	30"	\$1,572
FZFMBS.3653	53"	36"	\$1,766
FZFMBS.4253	53"	42"	\$1,960
FZFMBS.4853	53"	48"	\$2,153

#### 60" HIGH

PART #	HEIGHT	WIDTH	LIST
FZFMBS.3060	60"	30"	\$1,701
FZFMBS.3660	60"	36"	\$1,960
FZFMBS.4260	60"	42"	\$2,180
FZFMBS.4860	60"	48"	\$2,399

## SHIELD Freestanding Markerboard Panel Casters

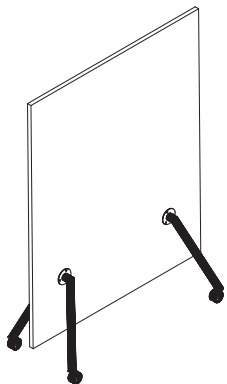

### DESCRIPTION

Freestanding markerboard panel with casters.

### NOTES

- Dimensions are actual
- Markerboard is 3/4" thick
- Legs are cloud white, casters are white
- Includes 4 locking casters

### SPECIFICATION OPTIONS

**product #:** see charts below

### ORDER EXAMPLE

**product #:** FZFMBSMOB.4845

#### 45" HIGH

PART #	HEIGHT	WIDTH	LIST
FZFMBSMOB.4245	45"	42"	\$1,890
FZFMBSMOB.4845	45"	48"	\$2,056

#### 53" HIGH

PART #	HEIGHT	WIDTH	LIST
FZFMBSMOB.4253	53"	42"	\$2,096
FZFMBSMOB.4853	53"	48"	\$2,290

#### 60" HIGH

PART #	HEIGHT	WIDTH	LIST
FZFMBSMOB.4260	60"	42"	\$2,276
FZFMBSMOB.4860	60"	48"	\$2,494

## Shield Acrylic Screen, Freestanding, 1 7/8" Base

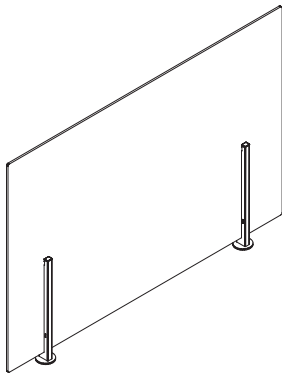

### DESCRIPTION

Shield clear acrylic screen with freestanding hardware attachment, 1 7/8" base.

### NOTES

- Freestanding hardware attaches with removable adhesive
- Round hardware base diameter is 1 7/8"
- Hardware is silver
- Clear acrylic screen, 5mm thick
- Actual screen size is less 1/2" high and 1/8" wide
- Sold individually

### SPECIFICATION OPTIONS

**product #:** see charts below

### ORDER EXAMPLE

**product #:** FPSF2.1448-CL

### FREESTANDING SCREEN 14" HIGH CLEAR, 1 7/8" BASE

PART #	HEIGHT	WIDTH	LIST
FPSF2.1424-CL	14"	24"	\$415
FPSF2.1430-CL	14"	30"	\$430
FPSF2.1436-CL	14"	36"	\$445
FPSF2.1442-CL	14"	42"	\$461
FPSF2.1448-CL	14"	48"	\$477
FPSF2.1454-CL	14"	54"	\$493
FPSF2.1460-CL	14"	60"	\$507

### FREESTANDING SCREEN 24" HIGH CLEAR, 1 7/8" BASE

PART #	HEIGHT	WIDTH	LIST
FPSF2.2424-CL	24"	24"	\$459
FPSF2.2430-CL	24"	30"	\$485
FPSF2.2436-CL	24"	36"	\$513
FPSF2.2442-CL	24"	42"	\$539
FPSF2.2448-CL	24"	48"	\$565
FPSF2.2454-CL	24"	54"	\$593
FPSF2.2460-CL	24"	60"	\$619

## Shield Acrylic Screen, Freestanding, 4" Base

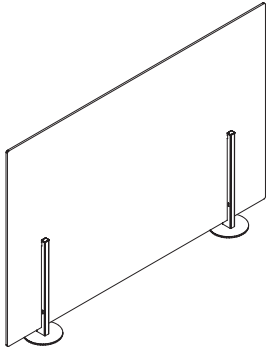

### DESCRIPTION

Shield clear acrylic screen with freestanding hardware attachment, 4" base.

### NOTES

- Freestanding hardware attaches with removable adhesive
- Round hardware base diameter is 4"
- Hardware is silver
- Clear acrylic screen, 5mm thick
- Actual screen size is less 1/2" high and 1/8" wide
- Sold individually

### SPECIFICATION OPTIONS

**product #:** see charts below

### ORDER EXAMPLE

**product #:** FPSF4.1448-CL

### FREESTANDING SCREEN 14" HIGH CLEAR, 4" BASE

PART #	HEIGHT	WIDTH	LIST
FPSF4.1424-CL	14"	24"	\$467
FPSF4.1430-CL	14"	30"	\$483
FPSF4.1436-CL	14"	36"	\$498
FPSF4.1442-CL	14"	42"	\$514
FPSF4.1448-CL	14"	48"	\$529
FPSF4.1454-CL	14"	54"	\$545
FPSF4.1460-CL	14"	60"	\$560

### FREESTANDING SCREEN 24" HIGH CLEAR, 4" BASE

PART #	HEIGHT	WIDTH	LIST
FPSF4.2424-CL	24"	24"	\$512
FPSF4.2430-CL	24"	30"	\$538
FPSF4.2436-CL	24"	36"	\$565
FPSF4.2442-CL	24"	42"	\$592
FPSF4.2448-CL	24"	48"	\$618
FPSF4.2454-CL	24"	54"	\$645
FPSF4.2460-CL	24"	60"	\$671

## Shield Acrylic Screen, Clamp

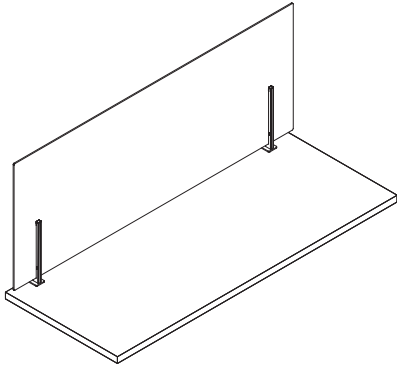

### DESCRIPTION

Shield clear acrylic screen with clamp hardware attachment.

### NOTES

- Clamp mount package attaches to the edge of a worksurface
- Clamp can be used on surfaces 1"-1.25" thick
- Hardware is silver
- Clear acrylic screen, 5mm thick
- Actual screen size is less 1/2" high and 1/8" wide
- Sold individually

### SPECIFICATION OPTIONS

**product #:** see charts below

### ORDER EXAMPLE

**product #:** FPSC.1448-CL

### CLAMP SCREEN 14" HIGH CLEAR

PART #	HEIGHT	WIDTH	LIST
FPSC.1422-CL	14"	22"	\$415
FPSC.1424-CL	14"	24"	\$415
FPSC.1428-CL	14"	28"	\$430
FPSC.1430-CL	14"	30"	\$430
FPSC.1436-CL	14"	36"	\$445
FPSC.1440-CL	14"	40"	\$461
FPSC.1442-CL	14"	42"	\$461
FPSC.1446-CL	14"	46"	\$477
FPSC.1448-CL	14"	48"	\$477
FPSC.1452-CL	14"	52"	\$493
FPSC.1454-CL	14"	54"	\$493
FPSC.1458-CL	14"	58"	\$507
FPSC.1460-CL	14"	60"	\$507

### CLAMP SCREEN 24" HIGH CLEAR

PART #	HEIGHT	WIDTH	LIST
FPSC.2422-CL	24"	22"	\$459
FPSC.2424-CL	24"	24"	\$459
FPSC.2428-CL	24"	28"	\$485
FPSC.2430-CL	24"	30"	\$485
FPSC.2436-CL	24"	36"	\$513
FPSC.2440-CL	24"	40"	\$539
FPSC.2442-CL	24"	42"	\$539
FPSC.2446-CL	24"	46"	\$565
FPSC.2448-CL	24"	48"	\$565
FPSC.2452-CL	24"	52"	\$593
FPSC.2454-CL	24"	54"	\$593
FPSC.2458-CL	24"	58"	\$619
FPSC.2460-CL	24"	60"	\$619



## Shield Acrylic Screen, Panel-Mounted

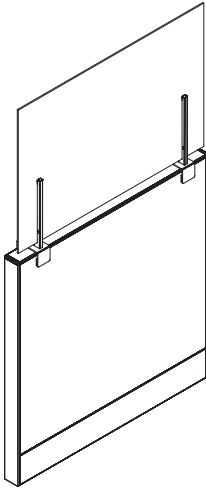

### DESCRIPTION

Shield clear acrylic screen with panel-mount hardware attachment.

### NOTES

- Panel hardware clamps on to most panels 1.6"-3.6" thick
- Select bracket size:
  - H1 for panels 1.6"-2" thick
  - H2 for panels 2.1"-2.5" thick
  - H3 for panels 2.6"-3" thick
  - H4 for panels 3.1"-3.6" thick
- For System 2 and Novo, use H1 brackets
- For Interra, use H3 brackets
- Hardware is silver
- Clear acrylic screen, 5mm thick
- Actual screen size is less 1/2" high and 1/8" wide
- Screen cannot be used at change of height location. Screen width does not accommodate change of height trim
- Sold individually

### SPECIFICATION OPTIONS

**product #:** see charts below  
**bracket size:** H1-H4, see sizes below

### ORDER EXAMPLE

**product #:** FPSP.1448-CL  
**bracket size:** H1

### PANEL SCREEN 14" HIGH CLEAR

PART #	HEIGHT	WIDTH	LIST
FPSP.1424-CL	14"	24"	\$440
FPSP.1430-CL	14"	30"	\$455
FPSP.1436-CL	14"	36"	\$470
FPSP.1442-CL	14"	42"	\$486
FPSP.1448-CL	14"	48"	\$502
FPSP.1454-CL	14"	54"	\$517
FPSP.1460-CL	14"	60"	\$533

### PANEL SCREEN 24" HIGH CLEAR

PART #	HEIGHT	WIDTH	LIST
FPSP.2424-CL	24"	24"	\$484
FPSP.2430-CL	24"	30"	\$510
FPSP.2436-CL	24"	36"	\$537
FPSP.2442-CL	24"	42"	\$564
FPSP.2448-CL	24"	48"	\$590
FPSP.2454-CL	24"	54"	\$617
FPSP.2460-CL	24"	60"	\$644

For use with  
**MY-HITE / UNIVERSAL**

## Worksurface Mounted Acrylic Screen (NEW)

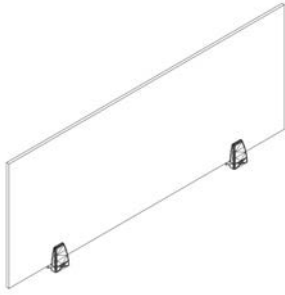

### DESCRIPTION

Surface mounted acrylic screens, including hardware

### NOTES

- Clear acrylic screen, 8mm thick
- Actual screen size is less 1/2" high and 1/8" wide
- Includes: (2) supporting brackets for screens up to 46"W, (3) supporting brackets for screens 48"W and wider.
- Mounts to any laminate/veneer worksurface top.
- Brackets attach permanently to the work top with bolts

### SPECIFICATION OPTIONS

**product #:** see charts below  
**paint (brackets):** CW, BU, SV

### ORDER EXAMPLE

**product #:** FMHPLSC.1430-CL  
**paint:** SV Silver

### 14" H CLEAR

PART #	HEIGHT	WIDTH	LIST
FMHPLSC.1422-CL	14"	22"	\$388
FMHPLSC.1424-CL	14"	24"	\$396
FMHPLSC.1428-CL	14"	28"	\$412
FMHPLSC.1430-CL	14"	30"	\$419
FMHPLSC.1436-CL	14"	36"	\$441
FMHPLSC.1440-CL	14"	40"	\$485
FMHPLSC.1442-CL	14"	42"	\$485
FMHPLSC.1446-CL	14"	46"	\$527
FMHPLSC.1448-CL	14"	48"	\$527
FMHPLSC.1452-CL	14"	52"	\$572
FMHPLSC.1454-CL	14"	54"	\$572
FMHPLSC.1458-CL	14"	58"	\$572
FMHPLSC.1460-CL	14"	60"	\$572

### 16" H CLEAR

PART #	HEIGHT	WIDTH	LIST
FMHPLSC.1622-CL	16"	22"	\$401
FMHPLSC.1624-CL	16"	24"	\$409
FMHPLSC.1628-CL	16"	28"	\$426
FMHPLSC.1630-CL	16"	30"	\$435
FMHPLSC.1636-CL	16"	36"	\$460
FMHPLSC.1640-CL	16"	40"	\$510
FMHPLSC.1642-CL	16"	42"	\$510
FMHPLSC.1646-CL	16"	46"	\$553
FMHPLSC.1648-CL	16"	48"	\$553
FMHPLSC.1652-CL	16"	52"	\$604
FMHPLSC.1654-CL	16"	54"	\$604
FMHPLSC.1658-CL	16"	58"	\$604
FMHPLSC.1660-CL	16"	60"	\$604

**Worksurface Mounted Acrylic Screen (NEW)****18" H CLEAR**

PART #	HEIGHT	WIDTH	LIST
FMHPLSC.1822-CL	18"	22"	\$413
FMHPLSC.1824-CL	18"	24"	\$422
FMHPLSC.1828-CL	18"	28"	\$441
FMHPLSC.1830-CL	18"	30"	\$450
FMHPLSC.1836-CL	18"	36"	\$479
FMHPLSC.1840-CL	18"	40"	\$537
FMHPLSC.1842-CL	18"	42"	\$537
FMHPLSC.1846-CL	18"	46"	\$578
FMHPLSC.1848-CL	18"	48"	\$578
FMHPLSC.1852-CL	18"	52"	\$636
FMHPLSC.1854-CL	18"	54"	\$636
FMHPLSC.1858-CL	18"	58"	\$636
FMHPLSC.1860-CL	18"	60"	\$636

**24" H CLEAR**

PART #	HEIGHT	WIDTH	LIST
FMHPLSC.2422-CL	24"	22"	\$442
FMHPLSC.2424-CL	24"	24"	\$455
FMHPLSC.2428-CL	24"	28"	\$485
FMHPLSC.2430-CL	24"	30"	\$498
FMHPLSC.2436-CL	24"	36"	\$537
FMHPLSC.2440-CL	24"	40"	\$613
FMHPLSC.2442-CL	24"	42"	\$613
FMHPLSC.2446-CL	24"	46"	\$655
FMHPLSC.2448-CL	24"	48"	\$655
FMHPLSC.2452-CL	24"	52"	\$731
FMHPLSC.2454-CL	24"	54"	\$731
FMHPLSC.2458-CL	24"	58"	\$731
FMHPLSC.2460-CL	24"	60"	\$731

## Worksurface Mounted Screens, Fabric (NEW)

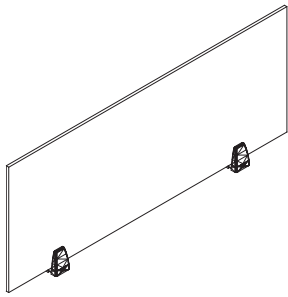

### DESCRIPTION

Surface mounted fabric screens, including hardware

### SPECIFICATION OPTIONS

**product #:** see charts below  
**Paint (Brackets)** CW, BU, SV  
**fabric:** see page 7 (Passage and Terrain fabric not approved for this application)

### NOTES

- Includes: (2) supporting brackets for screens up to 42"W, (3) supporting brackets for screens 48"W and wider.
- Mounts to any laminate/veneer worksurface top.
- Brackets attach permanently to the work top with bolts

### ORDER EXAMPLE

**product #:** FWSMTK.1424  
**paint:** SV Silver  
**fabric:** PF-101-2 Slide, Slate

### Fabric Screens, 14" HIGH

PART #	HEIGHT	WIDTH	LIST
FWSMTK.1424	14"	24"	\$255
FWSMTK.1430	14"	30"	\$268
FWSMTK.1436	14"	36"	\$322
FWSMTK.1442	14"	42"	\$322
FWSMTK.1448	14"	48"	\$373
FWSMTK.1454	14"	54"	\$454
FWSMTK.1460	14"	60"	\$479
FWSMTK.1466	14"	66"	\$479
FWSMTK.1472	14"	72"	\$505

### NOTES

- Screen mounts to any laminate/veneer worksurface top

### Fabric Screens, 14" HIGH

PART #	HEIGHT	WIDTH	LIST
FWSMTK.1422	14"	22"	\$255
FWSMTK.1428	14"	28"	\$268

### NOTES

- Screen mounts to any laminate/veneer worksurface top

### Fabric Screens, 24" HIGH

PART #	HEIGHT	WIDTH	LIST
FWSMTK.2422	24"	22"	\$515
FWSMTK.2424	24"	24"	\$518
FWSMTK.2428	24"	28"	\$541
FWSMTK.2430	24"	30"	\$544
FWSMTK.2436	24"	36"	\$635
FWSMTK.2442	24"	42"	\$664
FWSMTK.2448	24"	48"	\$740
FWSMTK.2454	24"	54"	\$849
FWSMTK.2460	24"	60"	\$926
FWSMTK.2466	24"	66"	\$936
FWSMTK.2472	24"	72"	\$1,013

### NOTES

- Screen mounts to any laminate/veneer worksurface top

## Worksurface Mounted Glass Screens, Clear

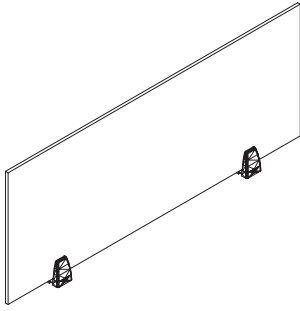

### DESCRIPTION

Surface mounted glass screens, including hardware.

### NOTES

- Actual screen size is less 1/2" high and 3/4" wide
- Includes: (2) supporting brackets for screens up to 42"W, (3) supporting brackets for screens 48"W and wider.
- Mounts to any laminate/veneer worksurface top.
- Brackets attach permanently to the work top with bolts

### SPECIFICATION OPTIONS

**product #** see charts below  
**Paint (Brackets)** CW, BU, SV

### ORDER EXAMPLE

**product #:** FWSMG.0824-CL  
**paint:** SV Silver

### 8" HIGH

PART #	HEIGHT	WIDTH	LIST
FWSMG.0824-CL	8"	24"	\$153
FWSMG.0830-CL	8"	30"	\$165
FWSMG.0836-CL	8"	36"	\$178
FWSMG.0842-CL	8"	42"	\$191
FWSMG.0848-CL	8"	48"	\$203
FWSMG.0854-CL	8"	54"	\$266
FWSMG.0860-CL	8"	60"	\$279
FWSMG.0866-CL	8"	66"	\$292
FWSMG.0872-CL	8"	72"	\$303

### NOTES

- Screen mounts to any laminate/veneer worksurface top

### 14" HIGH

PART #	HEIGHT	WIDTH	LIST
FWSMG.1424-CL	14"	24"	\$192
FWSMG.1430-CL	14"	30"	\$213
FWSMG.1436-CL	14"	36"	\$233
FWSMG.1442-CL	14"	42"	\$253
FWSMG.1448-CL	14"	48"	\$275
FWSMG.1454-CL	14"	54"	\$347
FWSMG.1460-CL	14"	60"	\$366
FWSMG.1466-CL	14"	66"	\$385
FWSMG.1472-CL	14"	72"	\$404

### NOTES

- Screen mounts to any laminate/veneer worksurface top

### 15" HIGH

PART #	HEIGHT	WIDTH	LIST
FWSMG.1522-CL	15"	22"	\$262
FWSMG.1528-CL	15"	28"	\$279

## Worksurface Mounted Glass Screens, Frosted

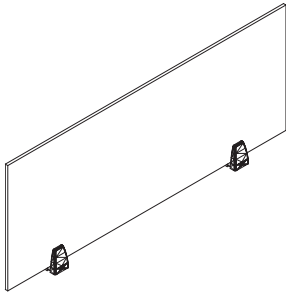

### DESCRIPTION

Surface mounted glass screens, including hardware

### NOTES

- Actual screen size is less 1/2" high and 3/4" wide
- Includes: (2) supporting brackets for screens up to 42"W, (3) supporting brackets for screens 48"W and wider.
- Mounts to any laminate/veneer worksurface top.
- Brackets attach permanently to the worktop with bolts

### SPECIFICATION OPTIONS

**product #:** see charts below  
**Paint (Brackets)** CW, BU, SV

### ORDER EXAMPLE

**product #:** FWSMG.0824-FR  
**paint:** SV Silver

### 8" HIGH

PART #	HEIGHT	WIDTH	LIST
FWSMG.0824-FR	8"	24"	\$214
FWSMG.0830-FR	8"	30"	\$242
FWSMG.0836-FR	8"	36"	\$270
FWSMG.0842-FR	8"	42"	\$300
FWSMG.0848-FR	8"	48"	\$328
FWSMG.0854-FR	8"	54"	\$383
FWSMG.0860-FR	8"	60"	\$394
FWSMG.0866-FR	8"	66"	\$404
FWSMG.0872-FR	8"	72"	\$415

### NOTES

- Screen mounts to any laminate/veneer worksurface top

### 14" HIGH

PART #	HEIGHT	WIDTH	LIST
FWSMG.1424-FR	14"	24"	\$299
FWSMG.1430-FR	14"	30"	\$348
FWSMG.1436-FR	14"	36"	\$397
FWSMG.1442-FR	14"	42"	\$444
FWSMG.1448-FR	14"	48"	\$495
FWSMG.1454-FR	14"	54"	\$552
FWSMG.1460-FR	14"	60"	\$594
FWSMG.1466-FR	14"	66"	\$635
FWSMG.1472-FR	14"	72"	\$677

### NOTES

- Screen mounts to any laminate/veneer worksurface top

### 15" HIGH

PART #	HEIGHT	WIDTH	LIST
FWSMG.1522-FR	15"	22"	\$364
FWSMG.1528-FR	15"	28"	\$407

## Privacy Screen, Fabric

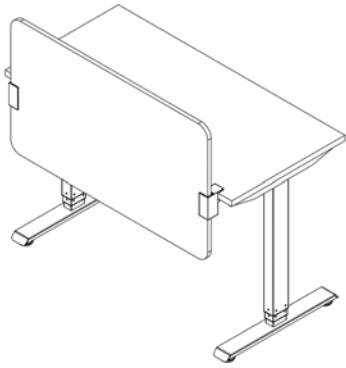

### DESCRIPTION

Work Surface mounted fabric covered privacy screen

### NOTES

- Fabric screen is non-tackable
- To use a wire manager on your My-Hite table with a fabric covered privacy screen, you must order "with gap".
- Actual screen is shorter than the worktop.
- Example: FPSFLUSH.2448 for use on 46"/48" width table, actual width of screen is 40".
- **Passage and Terrain fabric not approved for this application**

### SPECIFICATION OPTIONS

**product #** see charts below

**Paint (Brackets):** CW, BU, SV

**fabric:** see page 7 (Passage and Terrain fabric not approved for this application)

### ORDER EXAMPLE

**product #:** FPSFLUSH.2448

**brackets:** SV, Silver

**fabric:** PF-101-2 Slide, Slate

### Fabric Privacy Screen - Flush

Have grommet? Go flush

PART #	HEIGHT	WIDTH	LIST
FPSFLUSH.2442	24"	34"	\$505
FPSFLUSH.2448	24"	40"	\$547
FPSFLUSH.2454	24"	46"	\$589
FPSFLUSH.2460	24"	52"	\$633
FPSFLUSH.2466	24"	58"	\$676
FPSFLUSH.2472	24"	64"	\$719

### NOTES

- Privacy screen sits flush with the back of the worktop.
- Privacy screen is 8" shorter than free standing top width and 6" shorter than a worksurface from a paneled system.
- Example:
- FSQAHT-2460 order FPSFLUSH.2460 (actual width 52')

### Fabric Privacy Screen with Wire Management Gap

Need space between the screen and top? Add gap

PART #	HEIGHT	WIDTH	LIST
FPSGAP.2442	24"	34"	\$505
FPSGAP.2448	24"	40"	\$547
FPSGAP.2454	24"	46"	\$589
FPSGAP.2460	24"	52"	\$633
FPSGAP.2466	24"	58"	\$676
FPSGAP.2472	24"	64"	\$719

### NOTES

- With 1" gap at back of worksurface for cord/wire management.

Example:

1. FSQAHT-2460 order FPSGAP.2460 (actual width 52')

- Privacy screen sits flush with the back of the worktop.

- Privacy screen is 8" shorter than free standing top width and 6" shorter than a worksurface from a paneled system.

Example:

1. FSQAHT-2460 order FPSGAP.2460 (actual width 52')



## Privacy Screen, Marker Board

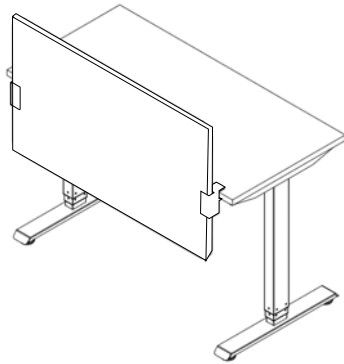

### DESCRIPTION

Work Surface mounted marker board privacy screen

### NOTES

- To use a wire manager on your My-Hite table with a marker board privacy screen, you must order "with gap".
- Actual screen is shorter than the worktop.
- Example: FMPSFLUSH.2448 for use on 46"/48" width table, actual width of screen is 40"

### SPECIFICATION OPTIONS

**product #:** see charts below  
**Paint (Brackets):** CW, BU, SV

### ORDER EXAMPLE

**product #:** FMPSFLUSH.2448  
**brackets:** SV, Silver

### Marker Board Privacy Screen - Flush

Have grommet? Go flush

PART #	HEIGHT	WIDTH	LIST
FMPSFLUSH.2442	24"	34"	\$654
FMPSFLUSH.2448	24"	40"	\$748
FMPSFLUSH.2454	24"	46"	\$843
FMPSFLUSH.2460	24"	52"	\$939
FMPSFLUSH.2466	24"	58"	\$1,034
FMPSFLUSH.2472	24"	64"	\$1,129

### NOTES

- Privacy screen sits flush with the back of the worktop.
- Privacy screen is 8" shorter than free standing top width and 6" shorter than a worksurface from a paneled system.

Example:

1. FSQAHT-2460 order FMPSFLUSH.2460 (actual width 52')

### Marker Board Privacy Screen- with Wire Management Gap

Need space between the screen and top? Add gap

PART #	HEIGHT	WIDTH	LIST
FMPGAP.2442	24"	34"	\$654
FMPGAP.2448	24"	40"	\$748
FMPGAP.2454	24"	46"	\$843
FMPGAP.2460	24"	52"	\$939
FMPGAP.2466	24"	58"	\$1,034
FMPGAP.2472	24"	64"	\$1,129

### NOTES

- With 1" gap at back of worksurface for cord/wire management.

Example:

1. FSQAHT-2460 order FMPGAP.2460 (actual width 52')
- Privacy screen sits flush with the back of the worktop.
  - Privacy screen is 8" shorter than free standing top width and 6" shorter than a worksurface from a paneled system.
- Example:
1. FSQAHT-2460 order FMPGAP.2460 (actual width 52')

## Privacy Screen, Laminate

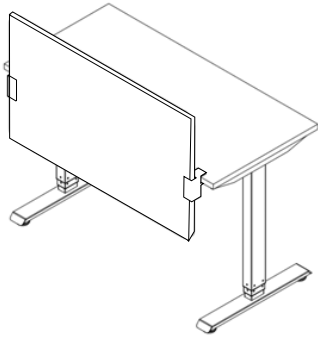

DESCRIPTION

Work Surface mounted laminate privacy screen

NOTES

- To use a wire manager on your My-Hite table with a laminate privacy screen, you must order "with gap".
- Actual screen is shorter than the worktop.

SPECIFICATION OPTIONS

**product #:** see charts below  
**paint (brackets):** CW, BU, SV  
**surface finish:** see page 9

ORDER EXAMPLE

**product #:** FLPSFLUSH.2442  
**paint:** SV Silver  
**surface finish:** M10 Espresso

### Laminate Privacy Screen - Flush

Have grommet? Go flush

PART #	HEIGHT	WIDTH	LIST
FLPSFLUSH.2442	24"	34"	\$344
FLPSFLUSH.2448	24"	40"	\$383
FLPSFLUSH.2454	24"	46"	\$421
FLPSFLUSH.2460	24"	52"	\$459
FLPSFLUSH.2466	24"	58"	\$498
FLPSFLUSH.2472	24"	64"	\$536

NOTES

- Privacy screen sits flush with the back of the worktop.
- Privacy screen is 8" shorter than free standing top width and 6" shorter than a worksurface from a paneled system.

Example:

1. FSQAHT-2460 order FPSFLUSH.2460 (actual width 52")

### Laminate Privacy Screen - with Wire Management Gap

Need space between the screen and top? Add gap

PART #	HEIGHT	WIDTH	LIST
FLPSGAP.2442	24"	34"	\$344
FLPSGAP.2448	24"	40"	\$383
FLPSGAP.2454	24"	46"	\$421
FLPSGAP.2460	24"	52"	\$459
FLPSGAP.2466	24"	58"	\$498
FLPSGAP.2472	24"	64"	\$536

NOTES

- With 1" gap at back of worksurface for cord/wire management.

Example:

1. FSQAHT-2460 order FPSGAP.2460 (actual width 52")

- Privacy screen sits flush with the back of the worktop.
- Privacy screen is 8" shorter than free standing top width and 6" shorter than a worksurface from a paneled system.

Example:

1. FSQAHT-2460 order FLPSGAP.2460 (actual width 52")

## Flyp Screens

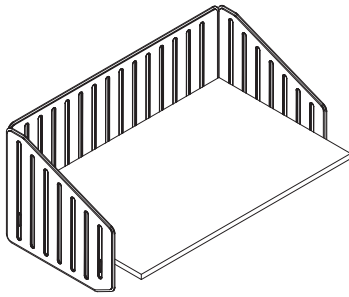

(3) Screens shown

### DESCRIPTION

Surface mounted PET screens, including hardware

### NOTES

- Screens sold individually
- Includes: (2) supporting brackets per screen
- Mounts to the underside of any laminate/veneer worksurface
- Screens can extend above or below worksurface
- Screen color is Sesame Black only
- Mounting hardware is Cool Grey
- Note actual widths of screens below

### SPECIFICATION OPTIONS

**product #:** see charts below

### ORDER EXAMPLE

**product #:** FPSFLYP.2258

### Flyp Screen

PART #	HEIGHT	WIDTH	LIST
FPSFLYP.2246	22"	46"	\$445
FPSFLYP.2258	22"	58"	\$622
FPSFLYP.2270	22"	70"	\$682

### NOTES

- Screen mounts to the underside of any laminate/veneer worksurface

### Flyp Side Screen

PART #	HEIGHT	WIDTH	LIST
FPSFLYP.2224	22"	23.5"	\$324

### NOTES

- Screen mounts to the underside of any laminate/veneer worksurface

For use with  
**VERITY**

## Supporting Cabinets

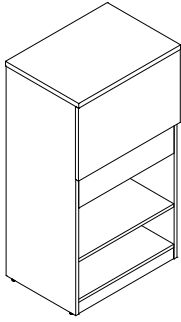

DESCRIPTION	SPECIFICATION OPTIONS
Storage support elements on one side.	<b>product #:</b> see charts below <b>front, casing &amp; worksurface finish (if applicable):</b> See surface laminates on page 9 <b>fabric:</b> See page 7
NOTES	ORDER EXAMPLE
<ul style="list-style-type: none"> <li>Order storage attachment bracket separately (see Verity pricebook).</li> <li>Specify worksurface finish for top and for casing</li> <li>Specify fabric on page 7</li> </ul>	<b>product #:</b> FVWSTT.1824 <b>front finish:</b> M1 Light Maple <b>worksurface finish:</b> M1 Light Maple <b>casing finish:</b> M29 Raven <b>fabric:</b> PF401-Silky-Natural

### Tackboard & Bookcase

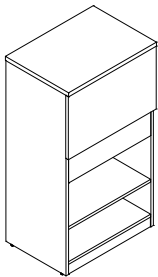

front shown

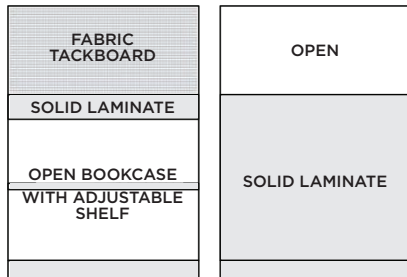

FRONT

BACK

PART #	HEIGHT	WIDTH	DEPTH	WT. (LBS)	LIST
FVWSTT.1824	45"	24.75"	18"	—	\$1,119
FVWSTT.1830	45"	30.75"	18"	—	\$1,287

#### NOTES

Supporting laminate cabinets with tackboard top and open bookcase bottom on one side, with open top and solid surface on the opposite side. Specify fabric for tackboard.

### Open & Bookcase

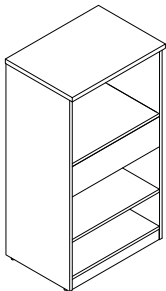

front shown

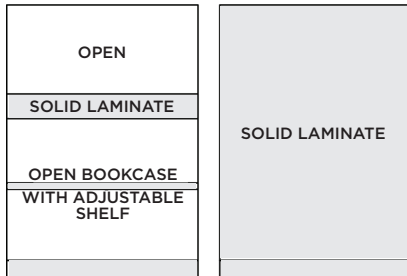

FRONT

BACK

PART #	HEIGHT	WIDTH	DEPTH	WT. (LBS)	LIST
FVWSTO.1824	45"	24.75"	18"	—	\$936
FVWSTO.1830	45"	30.75"	18"	—	\$1,038

#### NOTES

Supporting laminate cabinets with open top and open bookcase bottom on one side, with solid surface on the opposite side.

### Tackboard & Shared Bookcase

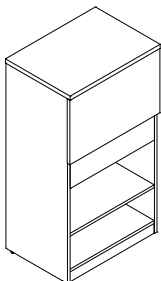

front shown

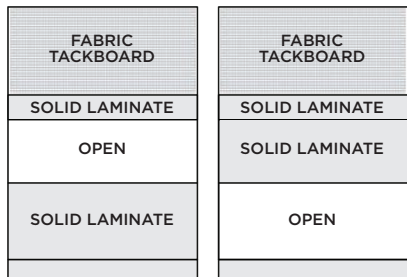

FRONT

BACK

PART #	HEIGHT	WIDTH	DEPTH	WT. (LBS)	LIST
FVWSTS.1824	45"	24.75"	18"	—	\$1,202
FVWSTS.1830	45"	30.75"	18"	—	\$1,414

#### NOTES

Supporting laminate cabinets with tackboard top and shared bookcase bottom on both sides. Shared bookcase has one open shelf and one solid surface on each side. Specify fabric for tackboard.

## Over-Worksurface Storage, Single-Sided

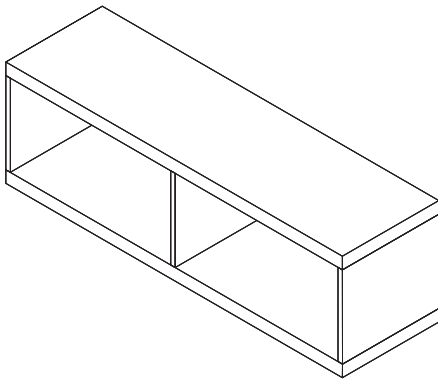

### DESCRIPTION

Single-sided laminate storage that is mounted above the worksurface, perpendicular to the spine. Available with open shelf or sliding door.

### NOTES

- Specify support (post leg or cabinet) separately
- Specify front finish and left/right pull location for storage door (if applicable)
- Specify pull when ordering
- Designer pull has color options: specify color when ordering.

### SPECIFICATION OPTIONS

**product #:** see charts below  
**front finish:** see page 9  
**top finish:** see page 9  
**casing finish:** see page 9  
**left or right (if applicable):** L for Left, R for Right  
**pull:** See below

### ORDER EXAMPLE

**product #:** FVOSDSN.1524  
**front finish:** M1 Light Maple  
**top finish:** M1 Light Maple  
**casing finish:** M1 Light Maple  
**left or right (if applicable):** L for Left  
**pull:** Wedge

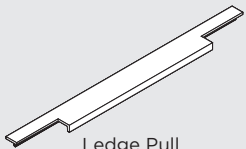
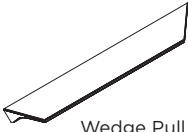
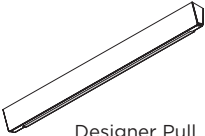
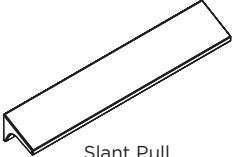
	DEFAULT PULL	PREMIUM PULLS		
STORAGE PULL OPTIONS	 Ledge Pull	 Wedge Pull	 Designer Pull • Cloud White/Red • Cloud White/Green • Cloud White/Grey	 Slant Pull

### WITH SLIDING DOOR 15" HIGH

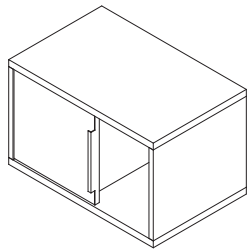

right hand shown

PART #	HEIGHT	WIDTH	DEPTH	WT. (LBS)	LIST
FVOSDSN.1524L	15"	24"	13.75"	—	\$563
FVOSDSN.1524R	15"	24"	13.75"	—	\$563
FVOSDSN.1530L	15"	30"	13.75"	—	\$622
FVOSDSN.1530R	15"	30"	13.75"	—	\$622
FVOSDSN.1548L	15"	48"	13.75"	—	\$814
FVOSDSN.1548R	15"	48"	13.75"	—	\$814
FVOSDSN.1560L	15"	60"	13.75"	—	\$1,051
FVOSDSN.1560R	15"	60"	13.75"	—	\$1,051
FVOSDSN.1572L	15"	72"	13.75"	—	\$1,141
FVOSDSN.1572R	15"	72"	13.75"	—	\$1,141

### NOTES

Laminate storage with sliding door and solid back  
 Specify L for left or R for right indicating door pull location.  
 Specify front finish for sliding door  
 Specify pull when ordering

**WITH OPEN SHELF  
15" HIGH**

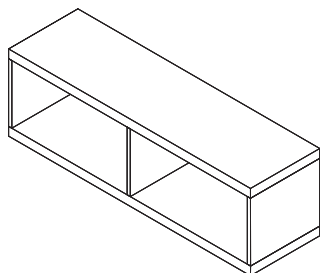

PART #	HEIGHT	WIDTH	DEPTH	WT. (LBS)	LIST
FVOSOSN.1524	15"	24"	13.75"	—	\$306
FVOSOSN.1530	15"	30"	13.75"	—	\$399
FVOSOSN.1548	15"	48"	13.75"	—	\$556
FVOSOSN.1560	15"	60"	13.75"	—	\$651
FVOSOSN.1572	15"	72"	13.75"	—	\$736

**NOTES**  
 Laminate storage with open shelf, and solid back  
 24"W and 30"W do not have a center divider.  
 48"W or wider have a center divider.

**WITH OPEN SHELF  
8" HIGH**

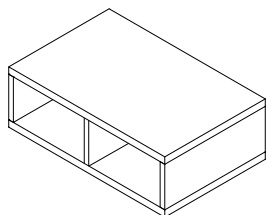

PART #	HEIGHT	WIDTH	DEPTH	WT. (LBS)	LIST
FVOSOS.0824	8"	24"	13.75"	—	\$204
FVOSOS.0830	8"	30"	13.75"	—	\$238
FVOSOS.0848	8"	48"	13.75"	—	\$373
FVOSOS.0860	8"	60"	13.75"	—	\$439
FVOSOS .0872	8"	72"	13.75"	—	\$498

**NOTES**  
 Laminate storage with open shelf, open back and center divider.  
 24"W and 30"W do not have a center divider.  
 48"W or wider have a center divider.

## Over-Worksurface Storage, Double-Sided

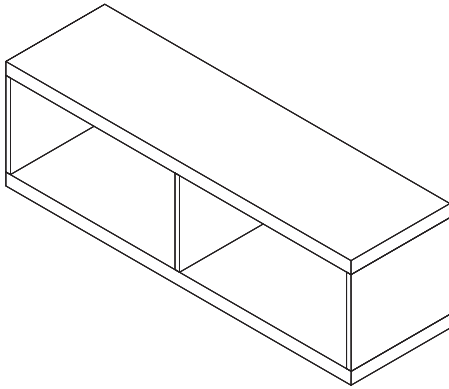

### DESCRIPTION

Double-sided (shared) storage that is mounted above the worksurface, perpendicular to the spine. Available with open shelf, or sliding door and markerboard.

### NOTES



- Specify support (post leg or cabinet) separately
- Specify front finish and left/right pull location for storage door (if applicable)
- Specify pull when ordering
- Designer pull has color options: specify color when ordering.

### SPECIFICATION OPTIONS

**product #:** see charts below  
**front finish:** see page 9  
**top finish:** see page 9  
**casing finish:** see page 9  
**left or right (if applicable):** L for Left, R for Right  
**pull:** See below

### ORDER EXAMPLE

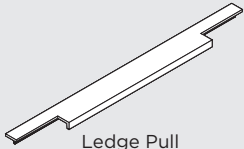
**product #:** FVOSDSH.1524  
**front finish:** M1 Light Maple  
**top finish:** M1 Light Maple  
**casing finish:** M1 Light Maple  
**left or right (if applicable):** L for Left  
**pull:** Wedge

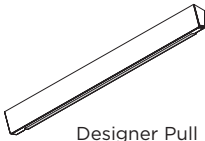
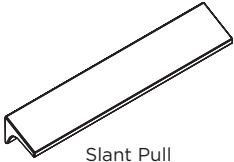
	DEFAULT PULL	PREMIUM PULLS		
STORAGE PULL OPTIONS	 Ledge Pull	 Wedge Pull	 Designer Pull • Cloud White/Red • Cloud White/Green • Cloud White/Grey	 Slant Pull

### WITH SLIDING DOOR 15" HIGH

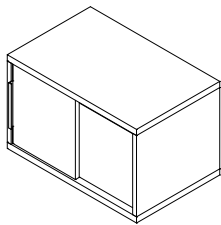

left hand shown

PART #	HEIGHT	WIDTH	DEPTH	WT. (LBS)	LIST	NOTES
FVOSDSH.1524L	15"	24"	13.75"	—	\$901	Laminate storage with sliding door and markerboard on each side
FVOSDSH.1524R	15"	24"	13.75"	—	\$901	
FVOSDSH.1530L	15"	30"	13.75"	—	\$1,003	Specify L for left or R for right indicating door pull location.
FVOSDSH.1530R	15"	30"	13.75"	—	\$1,003	
FVOSDSH.1548L	15"	48"	13.75"	—	\$1,340	Specify front finish for sliding door.
FVOSDSH.1548R	15"	48"	13.75"	—	\$1,340	
FVOSDSH.1560L	15"	60"	13.75"	—	\$1,541	Specify pull when ordering
FVOSDSH.1560R	15"	60"	13.75"	—	\$1,541	Designer pull has color options: specify color when ordering.
FVOSDSH.1572L	15"	72"	13.75"	—	\$1,697	
FVOSDSH.1572R	15"	72"	13.75"	—	\$1,697	

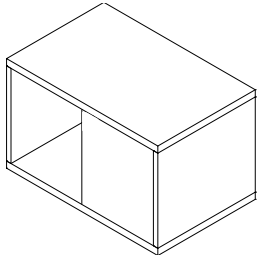

**WITH OPEN SHELF  
15" HIGH**

left hand shown

PART #	HEIGHT	WIDTH	DEPTH	WT. (LBS)	LIST
FVOSOSH.1524L	15"	24"	13.75"	—	\$276
FVOSOSH.1524R	15"	24"	13.75"	—	\$276
FVOSOSH.1530L	15"	30"	13.75"	—	\$276
FVOSOSH.1530R	15"	30"	13.75"	—	\$276
FVOSOSH.1548L	15"	48"	13.75"	—	\$458
FVOSOSH.1548R	15"	48"	13.75"	—	\$458
FVOSOSH.1560L	15"	60"	13.75"	—	\$496
FVOSOSH.1560R	15"	60"	13.75"	—	\$496
FVOSOSH.1572L	15"	72"	13.75"	—	\$554
FVOSOSH.1572R	15"	72"	13.75"	—	\$554

**NOTES**

Laminate storage with open shelf and markerboard on each side.

Specify L for left or R for right indicating open shelf location.

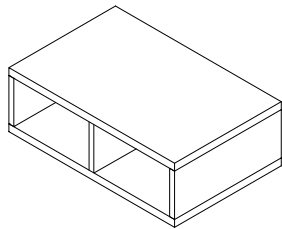
**WITH OPEN SHELF  
8" HIGH**

PART #	HEIGHT	WIDTH	DEPTH	WT. (LBS)	LIST
FVOSOS.0824	8"	24"	13.75"	—	\$204
FVOSOS.0830	8"	30"	13.75"	—	\$238
FVOSOS.0848	8"	48"	13.75"	—	\$373
FVOSOS.0860	8"	60"	13.75"	—	\$439
FVOSOS.0872	8"	72"	13.75"	—	\$498

**NOTES**

Laminate storage with open shelf, open back and center divider.

24"W and 30"W do not have a center divider.

48"W or wider have a center divider.

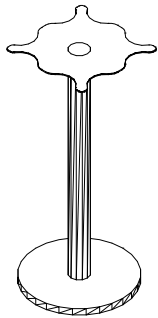
**SUPPORT COLUMN LEG  
WITH DISC BASE**

PART #	HEIGHT	WIDTH	DEPTH	WT. (LBS)	LIST
FVSL.3	29.5"	3"/14"	—	—	\$453

**NOTES**

Supporting column leg with disc base for over-worksurface mounted cabinets.

3"W column, 14"W disc base.

Supporting leg available in paint finish

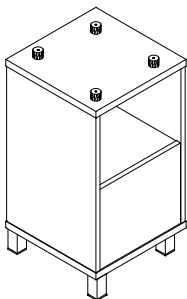
**SUPPORT CABINET**

PART #	HEIGHT	WIDTH	DEPTH	WT. (LBS)	LIST
FVSC.1416	29.5"	15.5"	13.75"	—	\$805

**NOTES**

Supporting cabinet for over-worksurface mounted cabinets.

Specify top, casing and front finish

Opposite side is closed at top and open at bottom.

## Track Mounted Fabric Screen

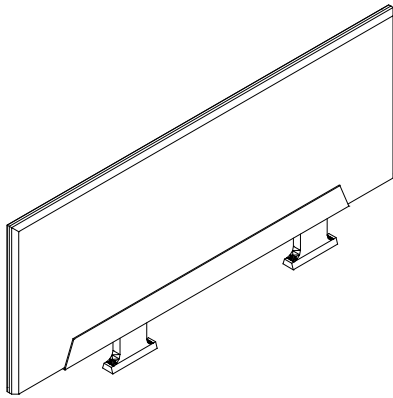

### DESCRIPTION

Accessories mounted to the center track.  
Please view individual product details below.

### SPECIFICATION OPTIONS

**product #:** see charts below  
**fabric (if applicable):** see page 7  
**(Passage and Terrain fabric not approved for this application)**  
**paint (bracket):** CW, BU, or SV

### NOTES

Mounts to Verity track  
Support brackets available in CW, BU and SV  
A shelf cannot be installed in the same position as the track mounted tackboard.

### ORDER EXAMPLE

**product #:** FVTKBDT.1560  
**fabric:** PF-101-2 Slide, Slate  
**paint:** CW Cloud White

**Passage and Terrain fabric not approved for this application**

### FABRIC TACKBOARD 15" (track-mounted)

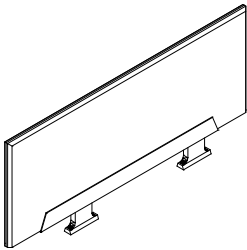

PART #	HEIGHT	WIDTH	DEPTH	WT. (LBS)	LIST
FVTKBDT.1536	15"	34"	1.25"	—	\$339
FVTKBDT.1542	15"	40"	1.25"	—	\$381
FVTKBDT.1548	15"	46"	1.25"	—	\$410
FVTKBDT.1554	15"	52"	1.25"	—	\$483
FVTKBDT.1560	15"	58"	1.25"	—	\$522
FVTKBDT.1566	15"	64"	1.25"	—	\$563
FVTKBDT.1572	15"	70"	1.25"	—	\$587

### NOTES

Specify fabric on page 7.

### FABRIC TACKBOARD 18" (track-mounted)

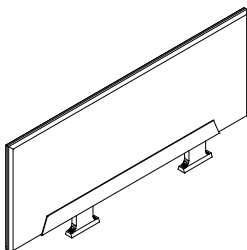

PART #	HEIGHT	WIDTH	DEPTH	WT. (LBS)	LIST
FVTKBDT.1836	18"	34"	1.25"	—	\$373
FVTKBDT.1842	18"	40"	1.25"	—	\$418
FVTKBDT.1848	18"	46"	1.25"	—	\$452
FVTKBDT.1854	18"	52"	1.25"	—	\$532
FVTKBDT.1860	18"	58"	1.25"	—	\$575
FVTKBDT.1866	18"	64"	1.25"	—	\$630
FVTKBDT.1872	18"	70"	1.25"	—	\$646

### NOTES

Specify fabric on page 7.

Support brackets are available in Cloud White, Silver and Black Umber.

### FABRIC TACKBOARD 20" (track-mounted)

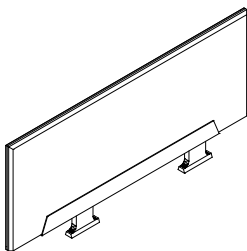

PART #	HEIGHT	WIDTH	DEPTH	WT. (LBS)	LIST
FVTKBDT.2036	20"	34"	1.25"	—	\$389
FVTKBDT.2042	20"	40"	1.25"	—	\$438
FVTKBDT.2048	20"	46"	1.25"	—	\$473
FVTKBDT.2054	20"	52"	1.25"	—	\$555
FVTKBDT.2060	20"	58"	1.25"	—	\$601
FVTKBDT.2066	20"	64"	1.25"	—	\$647
FVTKBDT.2072	20"	70"	1.25"	—	\$676

### NOTES

Specify fabric on page 7.

Support brackets are available in Cloud White, Silver and Black Umber.

## Track-Mounted Glass Screen

### CLEAR GLASS SCREEN (track-mounted)

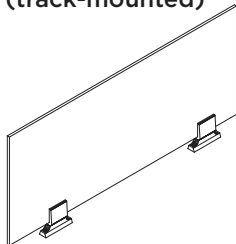

PART #	HEIGHT	WIDTH	DEPTH	WT. (LBS)	LIST	NOTES
FVGSTCL.1524	15"	23.25"	1.25"	—	\$194	Glass is clear.
FVGSTCL.1530	15"	29.25"	1.25"	—	\$222	For 78" tops, order 1 piece of 42" glass and 1 piece of 36" glass.
FVGSTCL.1536	15"	35.25"	1.25"	—	\$249	
FVGSTCL.1542	15"	41.25"	1.25"	—	\$275	For 84" tops, order 2 pieces of 42" glass.
FVGSTCL.1548	15"	47.25"	1.25"	—	\$304	
FVGSTCL.1554	15"	53.25"	1.25"	—	\$358	For 96" tops, order 2 pieces of 48" glass.
FVGSTCL.1560	15"	59.25"	1.25"	—	\$358	
FVGSTCL.1566	15"	65.25"	1.25"	—	\$405	
FVGSTCL.1572	15"	71.25"	1.25"	—	\$405	

### FROSTED GLASS SCREEN (track-mounted)

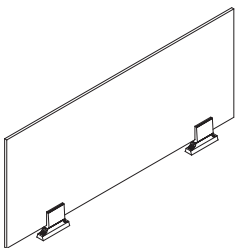

PART #	HEIGHT	WIDTH	DEPTH	WT. (LBS)	LIST	NOTES
FVGSTFR.1524	15"	23.25"	1.25"	—	\$294	Glass is frosted.
FVGSTFR.1530	15"	29.25"	1.25"	—	\$348	For 78" tops, order 1 piece of 42" glass and 1 piece of 36" glass.
FVGSTFR.1536	15"	35.25"	1.25"	—	\$400	
FVGSTFR.1542	15"	41.25"	1.25"	—	\$454	For 84" tops, order 2 pieces of 42" glass.
FVGSTFR.1548	15"	47.25"	1.25"	—	\$508	
FVGSTFR.1554	15"	53.25"	1.25"	—	\$645	For 96" tops, order 2 pieces of 48" glass.
FVGSTFR.1560	15"	59.25"	1.25"	—	\$645	
FVGSTFR.1566	15"	65.25"	1.25"	—	\$751	
FVGSTFR.1572	15"	71.25"	1.25"	—	\$751	

## Track Mounted Acrylic Screen (NEW)

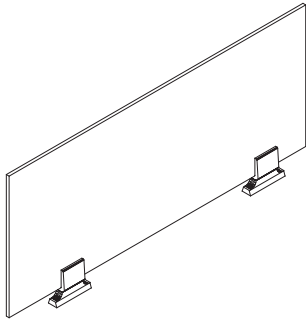

### DESCRIPTION

Track mounted acrylic screens, including hardware

### NOTES

- Mounts to Verity track
- Clear acrylic screen, 8mm thick
- Actual screen size is less 1/2" high and 1/8" wide

### SPECIFICATION OPTIONS

**product #:** see charts below  
**paint (brackets):** CW, BU, SV

### ORDER EXAMPLE

**product #:** FVSMPLSC.2422-CL  
**paint:** CW Cloud White

### 24" H CLEAR

PART #	HEIGHT	WIDTH	LIST
FVTMPLSC.2424-CL	24"	24"	\$438
FVTMPLSC.2430-CL	24"	30"	\$478
FVTMPLSC.2436-CL	24"	36"	\$519
FVTMPLSC.2442-CL	24"	42"	\$559
FVTMPLSC.2448-CL	24"	48"	\$600
FVTMPLSC.2454-CL	24"	54"	\$640
FVTMPLSC.2460-CL	24"	60"	\$681
FVTMPLSC.2466-CL	24"	66"	\$721
FVTMPLSC.2472-CL	24"	72"	\$762

## Worksurface Mounted Acrylic Screen (NEW)

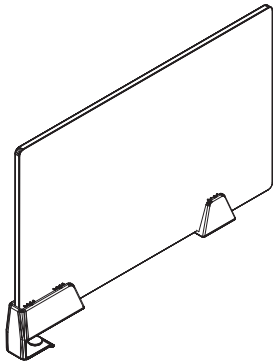

### DESCRIPTION

Surface mounted acrylic screens, including hardware

### NOTES

- Removable worksurface screen with clamp
- Clear acrylic screen, 8mm thick
- Actual screen size is less 1/2" high and 1/8" wide

### SPECIFICATION OPTIONS

**product #:** see charts below  
**edge finish:** see page 9  
**worksurface finish:** see page 9

### ORDER EXAMPLE

**product #:** FVSMPLSC.2422-CL

### 24" H CLEAR

PART #	HEIGHT	WIDTH	LIST
FVSMPLSC.2422-CL	24"	22"	\$421
FVSMPLSC.2428-CL	24"	28"	\$461

## Worksurface-Mounted Fabric Tackboard

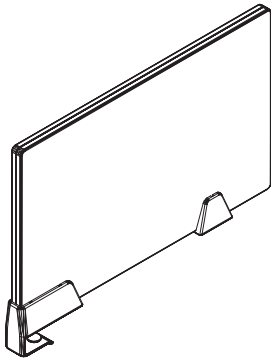

DESCRIPTION

Accessories mounted to the worksurface.

SPECIFICATION OPTIONS

**product #:** see charts below  
**fabric:** See page 7 (Passage and Terrain fabric not approved for this application).  
**finish:** CW, BU, SV

NOTES

- Removable worksurface screen with clamp

ORDER EXAMPLE

**product #:** FVTKBDW.1522  
**fabric:** PF401-1 Silky-Natural  
**finish:** CW Cloud White

### FABRIC TACKBOARD 15" (surface-mounted)

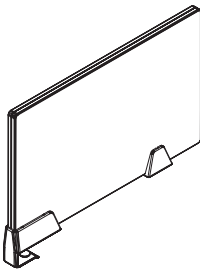

PART #	HEIGHT	WIDTH	DEPTH	WT. (LBS)	LIST
FVTKBDW.1522	15"	22"	1"	—	\$227
FVTKBDW.1528	15"	28"	1"	—	\$281

### FABRIC TACKBOARD 18" (surface-mounted)

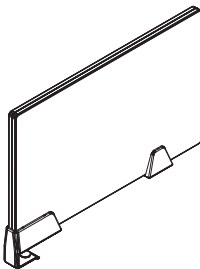

PART #	HEIGHT	WIDTH	DEPTH	WT. (LBS)	LIST
FVTKBDW.1822	18"	22"	1"	—	\$250
FVTKBDW.1828	18"	28"	1"	—	\$308

### FABRIC TACKBOARD 20" (surface-mounted)

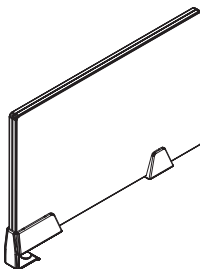

PART #	HEIGHT	WIDTH	DEPTH	WT. (LBS)	LIST
FVTKBDW.2022	20"	22"	1"	—	\$261
FVTKBDW.2028	20"	28"	1"	—	\$322

## Worksurface-Mounted Glass Screen

### CLEAR GLASS SCREEN (surface-mounted)

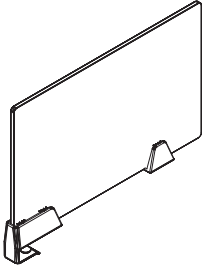

PART #	HEIGHT	WIDTH	DEPTH	WT. (LBS)	LIST	NOTES
FVGSWCL.1522	15"	22"	1"	—	\$249	Glass is clear.
FVGSWCL.1528	15"	28"	1"	—	\$310	Includes hardware.

### FROSTED GLASS SCREEN (surface-mounted)

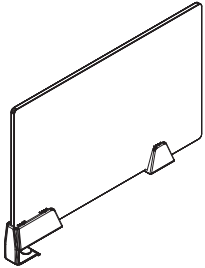

PART #	HEIGHT	WIDTH	DEPTH	WT. (LBS)	LIST	NOTES
FVGSWFR.1522	15"	22"	1"	—	\$344	Glass is frosted.
FVGSWFR.1528	15"	28"	1"	—	\$386	Includes hardware.

### MARKERBOARD SCREEN (surface-mounted)

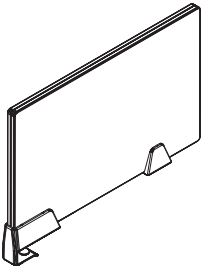

PART #	HEIGHT	WIDTH	DEPTH	WT. (LBS)	LIST	NOTES
FVMKRW.1522	15"	22"	1"	—	\$340	Markerboard with write and erase surface.
FVMKRW.1528	15"	28"	1"	—	\$441	Includes hardware.

For use with  
**INTERRA**



## Stacking Frames

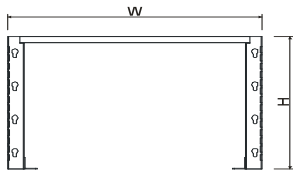
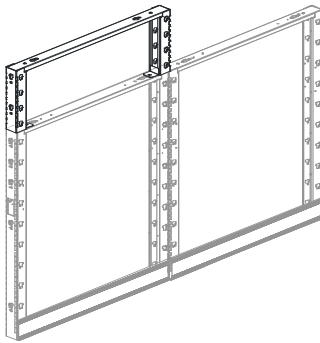

### DESCRIPTION

Stacking Frame attaches to the top of a Standard Frame, and holds individual tiles on both sides.

### NOTES

- Up to two stacking frames can be added to a base frame for a combined height of 45, 53, 61, 69, or 85
- Specify connector to match combined height
- Order change of height trim if needed
- One stacking frame IS load bearing if next to a connector of another frame of equal height
- Two stacking frames are NOT load bearing and must be placed adjacent to another frame or connector of the same height or taller
- Attachment hardware included
- Top cap from base frame is installed on stacking frame
- Stacking frames can accept fabric, perforated metal, stacking window, or rail tiles only

### SPECIFICATION OPTIONS

**product #:** see charts below

### ORDER EXAMPLE

**product #:** FISF.1624

PART #	HEIGHT	WIDTH	DEPTH	PRICE
FISF.1624	16-3/4"	24"	1-11/16"	\$72
FISF.1630	16-3/4"	30"	1-11/16"	\$75
FISF.1636	16-3/4"	36"	1-11/16"	\$78
FISF.1642	16-3/4"	42"	1-11/16"	\$81
FISF.1648	16-3/4"	48"	1-11/16"	\$85

### NOTES

Stacking frames can accept fabric, perforated metal, stacking window, or rail tiles only

## Perforated Metal Tile

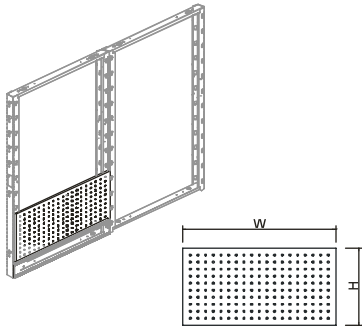

### DESCRIPTION

Perforated Metal Tile has round holes. It attaches to one side of a frame.

### NOTES

- Surface is magnetic.
- Tile may be placed at any position along the frame.

### SPECIFICATION OPTIONS

**product #:** see charts below  
**paint:** CW, BU SV

### ORDER EXAMPLE

**product #:** FIPMT.0824  
**paint:** CW

### 8"H

PART #	HEIGHT	WIDTH	DEPTH	PRICE
FIPMT.0824	8"	24"	7/16"	\$49
FIPMT.0830	8"	30"	7/16"	\$56
FIPMT.0836	8"	36"	7/16"	\$63
FIPMT.0842	8"	42"	7/16"	\$69
FIPMT.0848	8"	48"	7/16"	\$78

### 16"H

PART #	HEIGHT	WIDTH	DEPTH	PRICE
FIPMT.1624	16"	24"	7/16"	\$82
FIPMT.1630	16"	30"	7/16"	\$97
FIPMT.1636	16"	36"	7/16"	\$109
FIPMT.1642	16"	42"	7/16"	\$123
FIPMT.1648	16"	48"	7/16"	\$137

### 24"H

PART #	HEIGHT	WIDTH	DEPTH	PRICE
FIPMT.2424	24"	24"	7/16"	\$116
FIPMT.2430	24"	30"	7/16"	\$136
FIPMT.2436	24"	36"	7/16"	\$157
FIPMT.2442	24"	42"	7/16"	\$177
FIPMT.2448	24"	48"	7/16"	\$197

## Laminate Tile (NEW)

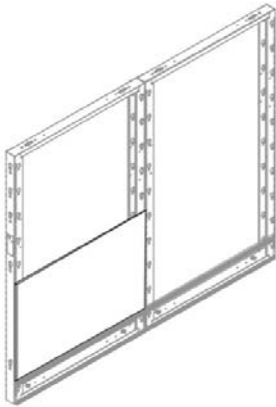

### DESCRIPTION

Laminate tile attaches to one side of a frame of the same width.

### SPECIFICATION OPTIONS

**product #:** see charts below  
**laminate:** see page 9  
**finish:** CW, BU, or SV

### NOTES

- Laminate tiles cannot be installed on stacking frames or wall strips
- Laminate tiles cannot be installed at the beltline (29" - 37" above the floor).
- **Exception:** 45"H frames - laminate tiles can be installed at the top of 45"H frames.
- Application is the same as markerboard  
See Interra Pricebook for details
- Grain direction is vertical

### ORDER EXAMPLE

**product #:** FILT.1624  
**laminate:** 7937-60 River Cherry  
**finish:** BU Black Umber

### 16" HIGH

PART #	HEIGHT	WIDTH	LIST
FILT.1624	16"	24"	\$327
FILT.1630	16"	30"	\$361
FILT.1636	16"	36"	\$426
FILT.1642	16"	42"	\$444
FILT.1648	16"	48"	\$462

### 32" HIGH

PART #	HEIGHT	WIDTH	LIST
FILT.3224	32"	24"	\$482
FILT.3230	32"	30"	\$542
FILT.3236	32"	36"	\$689
FILT.3242	32"	42"	\$695
FILT.3248	32"	48"	\$723

## Frameless Glass | Clear



DESCRIPTION

Frameless glass mounted to Interra panel top cap

SPECIFICATION OPTIONS

product #: see charts below

NOTES

- Frameless Glass screens are attached to the top of a single frame with included hardware.
- Matches the width of the frame.
- 3/4" gap between glass in a straight line
- 5/16" gap at change of height bracket
- Frameless glass will not fit between two taller panels at change of height. Frameless glass is narrow enough to accommodate adjacent change of height trim on one side, but not both.

ORDER EXAMPLE

product #: FIFG.0824-CL

### FRAMELESS GLASS 8" CLEAR

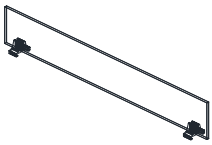

PART #	HEIGHT	WIDTH	DEPTH	PRICE
FIFG.0824-CL	8"	23-1/4"	—	\$341
FIFG.0830-CL	8"	29-1/4"	—	\$372
FIFG.0836-CL	8"	35-1/4"	—	\$399
FIFG.0842-CL	8"	41-1/4"	—	\$429
FIFG.0848-CL	8"	47-1/4"	—	\$458

NOTES

Includes attachment hardware, brushed finish.

Package contains 2 pieces of glass and 4 brackets.

### FRAMELESS GLASS 14" CLEAR



PART #	HEIGHT	WIDTH	DEPTH	PRICE
FIFG.1424-CL	14"	23-1/4"	—	\$433
FIFG.1430-CL	14"	29-1/4"	—	\$480
FIFG.1436-CL	14"	35-1/4"	—	\$526
FIFG.1442-CL	14"	41-1/4"	—	\$572
FIFG.1448-CL	14"	47-1/4"	—	\$625

NOTES

Includes attachment hardware, brushed finish.

Package contains 2 pieces of glass and 4 brackets.

## Frameless Glass | Frosted

### FRAMELESS GLASS 8" FROSTED

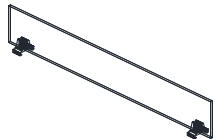

PART #	HEIGHT	WIDTH	DEPTH	PRICE	NOTES
FIFG.0824-FR	8"	23-1/4"	—	\$442	Includes attachment hardware, brushed finish.
FIFG.0830-FR	8"	29-1/4"	—	\$496	
FIFG.0836-FR	8"	35-1/4"	—	\$552	Package contains 2 pieces of glass and 4 brackets.
FIFG.0842-FR	8"	41-1/4"	—	\$605	
FIFG.0848-FR	8"	47-1/4"	—	\$661	

### FRAMELESS GLASS 14" FROSTED



PART #	HEIGHT	WIDTH	DEPTH	PRICE	NOTES
FIFG.1424-FR	14"	23-1/4"	—	\$605	Includes attachment hardware, brushed finish.
FIFG.1430-FR	14"	29-1/4"	—	\$699	
FIFG.1436-FR	14"	35-1/4"	—	\$793	Package contains 2 pieces of glass and 4 brackets.
FIFG.1442-FR	14"	41-1/4"	—	\$884	
FIFG.1448-FR	14"	47-1/4"	—	\$981	

## Top Cap | with Glass

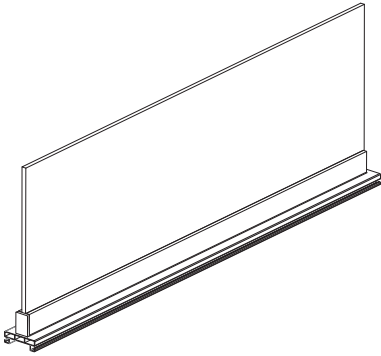

### DESCRIPTION

Top cap with glass attaches to the top of Interra frames. Glass is available in clear and frosted styles.

### NOTES

- Product includes (1) Top Cap and (1) piece of glass.
- Attaches to the top of Interra frames
- Available in 8" and 14" heights
- Choice of clear or frosted glass
- Specify Top Cap finish
- Frameless glass will not fit between two taller panels at change of height. Frameless glass is narrow enough to accommodate adjacent change of height trim on one side, but not both.
- Sold each

### SPECIFICATION OPTIONS

**product #:** see charts below  
**top cap finish:** CW, BU, SV

### ORDER EXAMPLE

**product #:** FIGTC.0824-CL  
**top cap finish:** CW

### 8"H, CLEAR

PART #	HEIGHT	WIDTH	DEPTH	PRICE
FIGTC.0824-CL	8"	24"	—	\$194
FIGTC.0830-CL	8"	30"	—	\$226
FIGTC.0836-CL	8"	36"	—	\$260
FIGTC.0842-CL	8"	42"	—	\$294
FIGTC.0848-CL	8"	48"	—	\$328
FIGTC.0854-CL	8"	54"	—	\$390
FIGTC.0860-CL	8"	60"	—	\$437
FIGTC.0866-CL	8"	66"	—	\$484
FIGTC.0872-CL	8"	72"	—	\$534

### NOTES

- Product includes (1) Top Cap and (1) piece of glass
- Attaches to the top of Interra frames
- 8" high Top Cap with clear glass
- Specify Top Cap finish

### 8"H, FROSTED

PART #	HEIGHT	WIDTH	DEPTH	PRICE
FIGTC.0824-FR	8"	24"	—	\$259
FIGTC.0830-FR	8"	30"	—	\$308
FIGTC.0836-FR	8"	36"	—	\$358
FIGTC.0842-FR	8"	42"	—	\$409
FIGTC.0848-FR	8"	48"	—	\$460
FIGTC.0854-FR	8"	54"	—	\$513
FIGTC.0860-FR	8"	60"	—	\$558
FIGTC.0866-FR	8"	66"	—	\$602
FIGTC.0872-FR	8"	72"	—	\$650

### NOTES

- Product includes (1) Top Cap and (1) piece of glass
- Attaches to the top of Interra frames
- 8" high Top Cap with frosted glass
- Specify Top Cap finish

**14"H, CLEAR**

PART #	HEIGHT	WIDTH	DEPTH	PRICE
FIGTC.1424-CL	14"	24"	—	\$235
FIGTC.1430-CL	14"	30"	—	\$277
FIGTC.1436-CL	14"	36"	—	\$318
FIGTC.1442-CL	14"	42"	—	\$359
FIGTC.1448-CL	14"	48"	—	\$403
FIGTC.1454-CL	14"	54"	—	\$474
FIGTC.1460-CL	14"	60"	—	\$529
FIGTC.1466-CL	14"	66"	—	\$582
FIGTC.1472-CL	14"	72"	—	\$640

## NOTES

- Product includes (1) Top Cap and (1) piece of glass
- Attaches to the top of Interra frames
- 14" high Top Cap with clear glass
- Specify Top Cap finish

**14"H, FROSTED**

PART #	HEIGHT	WIDTH	DEPTH	PRICE
FIGTC.1424-FR	14"	24"	—	\$348
FIGTC.1430-FR	14"	30"	—	\$419
FIGTC.1436-FR	14"	36"	—	\$490
FIGTC.1442-FR	14"	42"	—	\$560
FIGTC.1448-FR	14"	48"	—	\$635
FIGTC.1454-FR	14"	54"	—	\$688
FIGTC.1460-FR	14"	60"	—	\$767
FIGTC.1466-FR	14"	66"	—	\$845
FIGTC.1472-FR	14"	72"	—	\$926

## NOTES

- Product includes (1) Top Cap and (1) piece of glass
- Attaches to the top of Interra frames
- 14" high Top Cap with frosted glass
- Specify Top Cap finish

## Panel Mounted Acrylic Screen (NEW)

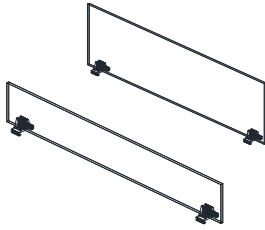

DESCRIPTION

Acrylic screen that attach to the top of a single frame

SPECIFICATION OPTIONS

product #: see charts below

NOTES

- Hardware included
- Clear acrylic screen, 8mm thick
- Actual screen size is less 1/2" high and 1/8" wide
- Screen will NOT fit at change of height location. Screen width will not accomodate the depth needed for change of height trim
- Sold each

ORDER EXAMPLE

product #: FIPLSC.1424-CL

### 14" H CLEAR

PART #	HEIGHT	WIDTH	LIST
FIPLSC.1424-CL	14"	24"	\$420
FIPLSC.1430-CL	14"	30"	\$444
FIPLSC.1436-CL	14"	36"	\$467
FIPLSC.1442-CL	14"	42"	\$492
FIPLSC.1448-CL	14"	48"	\$515

### 16" H CLEAR

PART #	HEIGHT	WIDTH	LIST
FIPLSC.1624-CL	16"	24"	\$434
FIPLSC.1630-CL	16"	30"	\$461
FIPLSC.1636-CL	16"	36"	\$488
FIPLSC.1642-CL	16"	42"	\$515
FIPLSC.1648-CL	16"	48"	\$542

### 18" H CLEAR

PART #	HEIGHT	WIDTH	LIST
FIPLSC.1824-CL	18"	24"	\$447
FIPLSC.1830-CL	18"	30"	\$478
FIPLSC.1836-CL	18"	36"	\$508
FIPLSC.1842-CL	18"	42"	\$539
FIPLSC.1848-CL	18"	48"	\$569

### 24" H CLEAR

PART #	HEIGHT	WIDTH	LIST
FIPLSC.2424-CL	24"	24"	\$488
FIPLSC.2430-CL	24"	30"	\$528
FIPLSC.2436-CL	24"	36"	\$569
FIPLSC.2442-CL	24"	42"	\$609
FIPLSC.2448-CL	24"	48"	\$650



For use with  
**SYSTEM 2**

## Frameless Glass

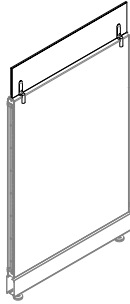

**DESCRIPTION**

Glass screen mounts to System 2 or Novo panel

**NOTES**

- Frameless Glass screens are attached to the top of a single frame with included hardware.
- Matches width of the frame.
- Package contains 2.
- Frameless glass will not fit between two taller panels at change of height. Frameless glass is narrow enough to accommodate adjacent change of height trim on one side, but not both.

**SPECIFICATION OPTIONS**

**product #:** see charts below

**ORDER EXAMPLE**

**product #:** F2FG.0824-CL

### FRAMELESS GLASS 8" CLEAR

PART #	HEIGHT	WIDTH	DEPTH	WT. (LBS)	PRICE
F2FG.0824-CL	8"	23-1/4"	—	—	\$367
F2FG.0830-CL	8"	29-1/4"	—	—	\$397
F2FG.0836-CL	8"	35-1/4"	—	—	\$424
F2FG.0842-CL	8"	41-1/4"	—	—	\$454
F2FG.0848-CL	8"	47-1/4"	—	—	\$483
F2FG.0860-CL	8"	59-1/4"	—	—	\$515

**NOTES**

- Includes attachment hardware, brushed finish.
- Package contains 2 pieces of glass and 4 brackets..

### FRAMELESS GLASS 14" CLEAR

PART #	HEIGHT	WIDTH	DEPTH	WT. (LBS)	PRICE
F2FG.1424-CL	14"	23-1/4"	—	—	\$454
F2FG.1430-CL	14"	29-1/4"	—	—	\$503
F2FG.1436-CL	14"	35-1/4"	—	—	\$550
F2FG.1442-CL	14"	41-1/4"	—	—	\$598
F2FG.1448-CL	14"	47-1/4"	—	—	\$649
F2FG.1460-CL	14"	59-1/4"	—	—	\$711

**NOTES**

- Includes attachment hardware, brushed finish.
- Package contains 2 pieces of glass and 4 brackets..

### FRAMELESS GLASS 8" FROSTED

PART #	HEIGHT	WIDTH	DEPTH	WT. (LBS)	PRICE
F2FG.0824-FR	8"	23-1/4"	—	—	\$422
F2FG.0830-FR	8"	29-1/4"	—	—	\$478
F2FG.0836-FR	8"	35-1/4"	—	—	\$533
F2FG.0842-FR	8"	41-1/4"	—	—	\$588
F2FG.0848-FR	8"	47-1/4"	—	—	\$643
F2FG.0860-FR	8"	59-1/4"	—	—	\$717

**NOTES**

- Includes attachment hardware, brushed finish.
- Package contains 2 pieces of glass and 4 brackets..

### FRAMELESS GLASS 14" FROSTED

PART #	HEIGHT	WIDTH	DEPTH	WT. (LBS)	PRICE
F2FG.1424-FR	14"	23-1/4"	—	—	\$588
F2FG.1430-FR	14"	29-1/4"	—	—	\$681
F2FG.1436-FR	14"	35-1/4"	—	—	\$774
F2FG.1442-FR	14"	41-1/4"	—	—	\$864
F2FG.1448-FR	14"	47-1/4"	—	—	\$963
F2FG.1460-FR	14"	59-1/4"	—	—	\$1,091

**NOTES**

- Includes attachment hardware, brushed finish.
- Package contains 2 pieces of glass and 4 brackets..

## Panel Mounted Acrylic Screen (NEW)

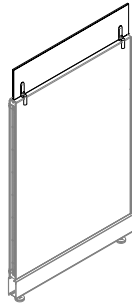

### DESCRIPTION

Acrylic screen that attach to the top of a single frame

### SPECIFICATION OPTIONS

**product #:** see charts below

### NOTES

- Hardware included
- Clear acrylic screen, 8mm thick
- Actual screen size is less 1/2" high and 1/8" wide
- Screen will NOT fit at change of height location. Screen width will not accomodate the depth needed for change of height trim
- Sold each

### ORDER EXAMPLE

**product #:** F2PLSC.1448-CL

### 14" H CLEAR

PART #	HEIGHT	WIDTH	LIST
F2PLSC.1424-CL	14"	24"	\$410
F2PLSC.1430-CL	14"	30"	\$435
F2PLSC.1436-CL	14"	36"	\$458
F2PLSC.1442-CL	14"	42"	\$482
F2PLSC.1448-CL	14"	48"	\$505
F2PLSC.1460-CL	14"	60"	\$553

### 16" H CLEAR

PART #	HEIGHT	WIDTH	LIST
F2PLSC.1624-CL	16"	24"	\$424
F2PLSC.1630-CL	16"	30"	\$452
F2PLSC.1636-CL	16"	36"	\$479
F2PLSC.1642-CL	16"	42"	\$505
F2PLSC.1648-CL	16"	48"	\$533
F2PLSC.1660-CL	16"	60"	\$587

### 18" H CLEAR

PART #	HEIGHT	WIDTH	LIST
F2PLSC.1824-CL	18"	24"	\$438
F2PLSC.1830-CL	18"	30"	\$468
F2PLSC.1836-CL	18"	36"	\$499
F2PLSC.1842-CL	18"	42"	\$529
F2PLSC.1848-CL	18"	48"	\$560
F2PLSC.1860-CL	18"	60"	\$621

### 24" H CLEAR

PART #	HEIGHT	WIDTH	LIST
F2PLSC.2424-CL	24"	24"	\$479
F2PLSC.2430-CL	24"	30"	\$519
F2PLSC.2436-CL	24"	36"	\$560
F2PLSC.2442-CL	24"	42"	\$600
F2PLSC.2448-CL	24"	48"	\$641
F2PLSC.2460-CL	24"	60"	\$722

For use with  
**NOVO**

## Frameless Glass Clear

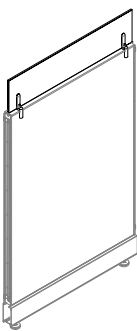

### DESCRIPTION

Glass screen mounts to System 2 or Novo panel

### SPECIFICATION OPTIONS

**product #:** see charts below

### NOTES

- Frameless Glass screens are attached to the top of a single frame with included hardware.
- Matches width of the frame.
- Package contains 2.
- Frameless glass will not fit between two taller panels at change of height. Frameless glass is narrow enough to accommodate adjacent change of height trim on one side, but not both.

### ORDER EXAMPLE

**product #:** F2FG.0824-CL

## FRAMELESS GLASS 8" CLEAR

PART #	HEIGHT	WIDTH	DEPTH	WT. (LBS)	LIST	NOTES
F2FG.0824-CL	8"	23-1/4"	—	—	\$367	Includes attachment hardware, brushed finish.
F2FG.0830-CL	8"	29-1/4"	—	—	\$397	
F2FG.0836-CL	8"	35-1/4"	—	—	\$424	Package contains 2 pieces of glass and 4 brackets.
F2FG.0842-CL	8"	41-1/4"	—	—	\$454	
F2FG.0848-CL	8"	47-1/4"	—	—	\$483	

## FRAMELESS GLASS 14" CLEAR

PART #	HEIGHT	WIDTH	DEPTH	WT. (LBS)	LIST	NOTES
F2FG.1424-CL	14"	23-1/4"	—	—	\$454	Includes attachment hardware, brushed finish.
F2FG.1430-CL	14"	29-1/4"	—	—	\$503	
F2FG.1436-CL	14"	35-1/4"	—	—	\$550	Package contains 2 pieces of glass and 4 brackets.
F2FG.1442-CL	14"	41-1/4"	—	—	\$598	
F2FG.1448-CL	14"	47-1/4"	—	—	\$649	

## Frameless Glass Frosted

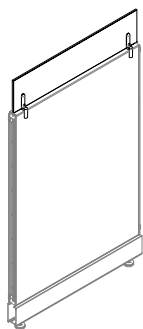

### DESCRIPTION

Glass screen mounts to System 2 or Novo panel

### SPECIFICATION OPTIONS

**product #:** see charts below

### NOTES

- Frameless Glass screens are attached to the top of a single frame with included hardware.
- Matches width of the frame.
- Package contains 2.
- Frameless glass will not fit between two taller panels at change of height. Frameless glass is narrow enough to accommodate adjacent change of height trim on one side, but not both.

### ORDER EXAMPLE

**product #:** F2FG.0824-FR

### FRAMELESS GLASS 8" FROSTED

PART #	HEIGHT	WIDTH	DEPTH	WT. (LBS)	LIST	NOTES
F2FG.0824-FR	8"	23-1/4"	—	—	\$422	Includes attachment hardware, brushed finish.
F2FG.0830-FR	8"	29-1/4"	—	—	\$478	
F2FG.0836-FR	8"	35-1/4"	—	—	\$533	Package contains 2 pieces of glass and 4 brackets.
F2FG.0842-FR	8"	41-1/4"	—	—	\$588	
F2FG.0848-FR	8"	47-1/4"	—	—	\$643	

### FRAMELESS GLASS 14" FROSTED

PART #	HEIGHT	WIDTH	DEPTH	WT. (LBS)	LIST	NOTES
F2FG.1424-FR	14"	23-1/4"	—	—	\$588	Includes attachment hardware, brushed finish.
F2FG.1430-FR	14"	29-1/4"	—	—	\$681	
F2FG.1436-FR	14"	35-1/4"	—	—	\$774	Package contains 2 pieces of glass and 4 brackets.
F2FG.1442-FR	14"	41-1/4"	—	—	\$864	
F2FG.1448-FR	14"	47-1/4"	—	—	\$963	

## Panel Mounted Acrylic Screen (NEW)

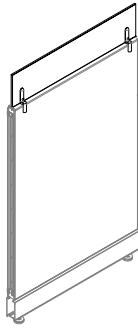

### DESCRIPTION

Acrylic screen that attach to the top of a single panel

### SPECIFICATION OPTIONS

**product #:** see charts below

### NOTES

- Hardware included
- Clear acrylic screen, 8mm thick
- Actual screen size is less 1/2" high and 1/8" wide
- Screen will NOT fit at change of height location. Screen width will not accomodate the depth needed for change of height trim
- Sold each

### ORDER EXAMPLE

**product #:** F2PLSC.1448-CL

### 14" H CLEAR

PART #	HEIGHT	WIDTH	LIST
F2PLSC.1424-CL	14"	24"	\$410
F2PLSC.1430-CL	14"	30"	\$435
F2PLSC.1436-CL	14"	36"	\$458
F2PLSC.1442-CL	14"	42"	\$482
F2PLSC.1448-CL	14"	48"	\$505

### 16" H CLEAR

PART #	HEIGHT	WIDTH	LIST
F2PLSC.1624-CL	16"	24"	\$424
F2PLSC.1630-CL	16"	30"	\$452
F2PLSC.1636-CL	16"	36"	\$479
F2PLSC.1642-CL	16"	42"	\$505
F2PLSC.1648-CL	16"	48"	\$533

### 18" H CLEAR

PART #	HEIGHT	WIDTH	LIST
F2PLSC.1824-CL	18"	24"	\$438
F2PLSC.1830-CL	18"	30"	\$468
F2PLSC.1836-CL	18"	36"	\$499
F2PLSC.1842-CL	18"	42"	\$529
F2PLSC.1848-CL	18"	48"	\$560

### 24" H CLEAR

PART #	HEIGHT	WIDTH	LIST
F2PLSC.2424-CL	24"	24"	\$479
F2PLSC.2430-CL	24"	30"	\$519
F2PLSC.2436-CL	24"	36"	\$560
F2PLSC.2442-CL	24"	42"	\$600
F2PLSC.2448-CL	24"	48"	\$641

# **FRÍANT**

## **Shield Screens and Panels**

Products that address the return to the office.