

FRONT VIEW

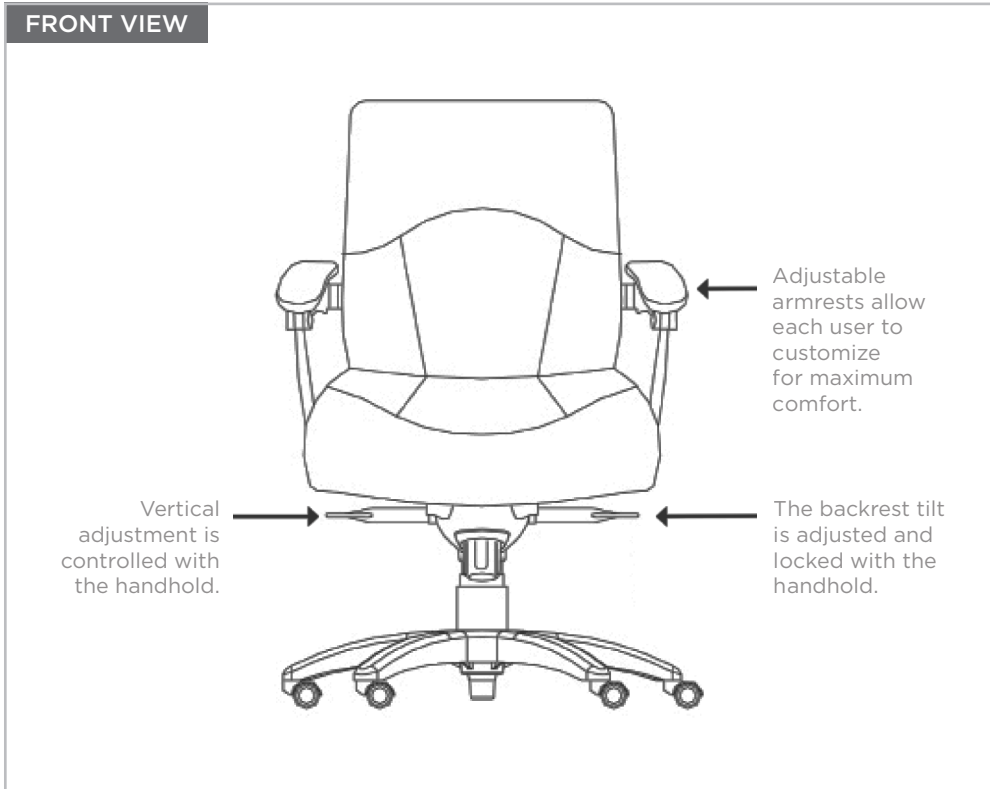

ADJUSTMENT KNOBS

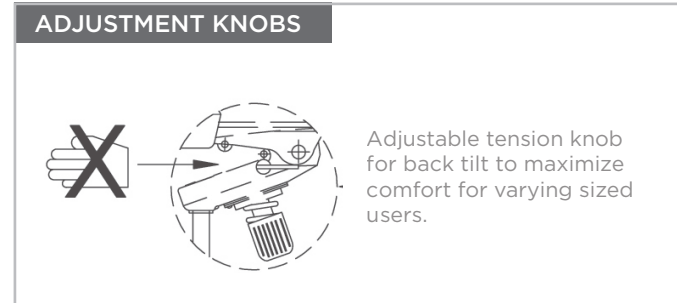



NOTE: Carefully check all parts according to the instructions before assembling. Please assemble carefully to avoid scratching surfaces, especially powder-coated surfaces.

Parts & Hardware

Item	Parts	Qty.	Hardware	Headrest Parts/Hardware	Qty.
A	Backrest	1	A	Screw 5/16" x 1-1/4"	2
B	Armrest L/R	1 ea	B	Screw 5/16" x 1"	2
C	Mechanism	1	C	Screw 5/16" x 3/4"	3
D	Seat Cushion	1	D	Screw 5/16" x 7/8"	2
E	Gas Lift	1	E	Screw 5/16" x 1-1/8"	2
F	Base	1	F	Flat Washer	5
G	Caster	5	G	Spring Washer	5
H	Telescoping Cover	1	H	Four-angle Washer	2
			I	L Shape Wrench	1
			J	T Shape Wrench	1
			K	Inverse Cup	2
			L	Big Cap	4
			M	Small Cap L/R	1 ea

ASSEMBLY GUIDE

Assembly Instructions

1. Attach the mechanism [C] to the seat cushion [D] to fasten with screws [A & B]. Screw [A] is for the front of the seat cushion and screw [B] is for the back of the seat cushion.
2. Attach caster [G] to the base [F]. Insert the gas lift [E] to the center hole of the 5 star base [F] and place telescoping cover [H] to the gas lift [E].
3. First add the gas lift [E] into the hole of the mechanism [C] that assembled in the seat cushion [D]. Then assemble the backrest [A] into the steel beneath the mechanism [C]. Insert screws.

Note: Do not tighten the screws until after assembling the arm rest.

Before fastening the screws, add the spring washer [G] and common washer [F] into the screw [C]. Make sure the steel shell of the backrest [A] and the steel mechanism [C] are at the same level.

4. Attach the armrest [B] to the chair, using instructions on the next page.

See next page for Armrest Assembly Guide.

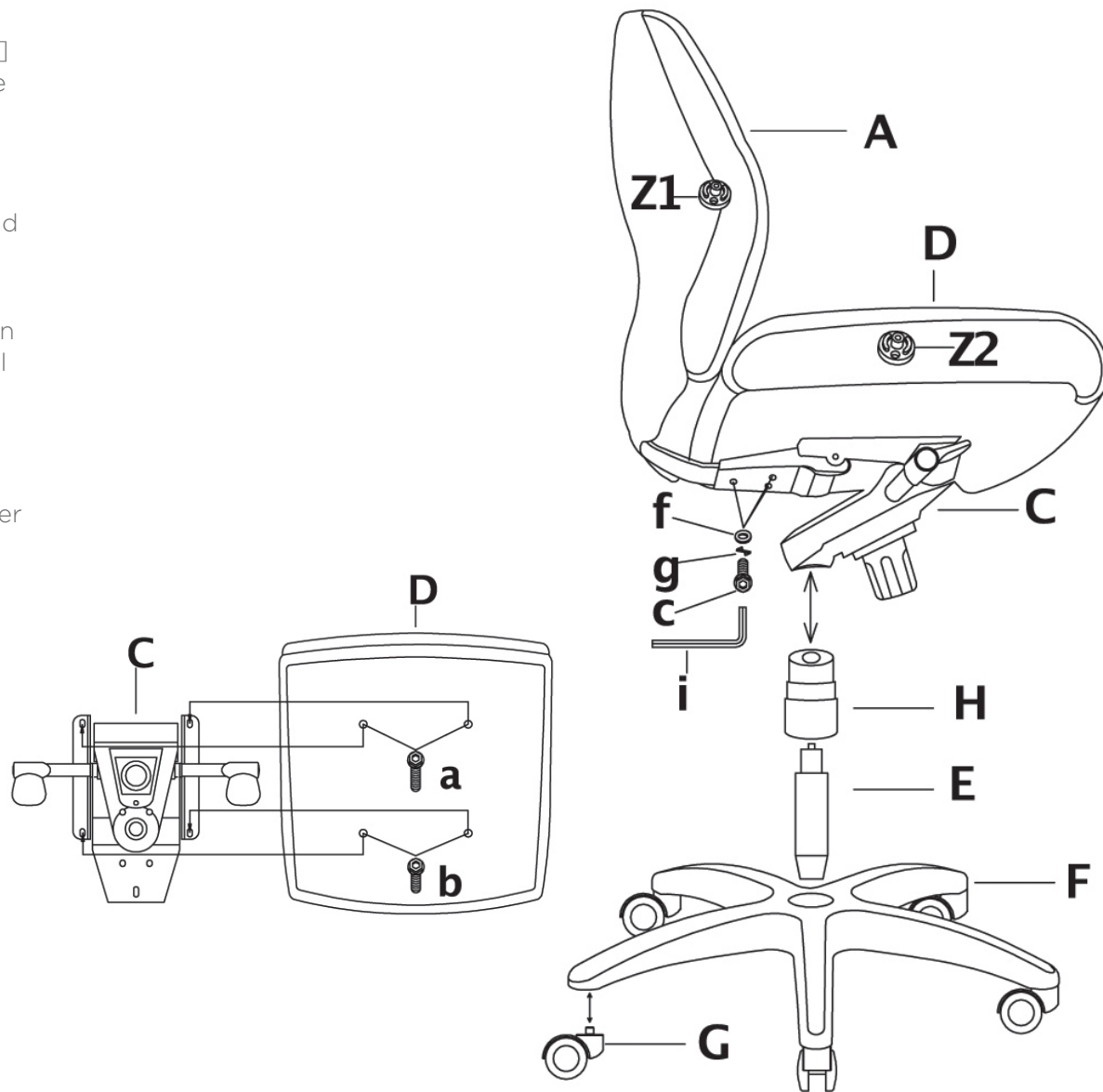

ASSEMBLY GUIDE

Armrest Assembly Instructions

1. Insert the armrest [B] into the circular of Z1 and Z2. Insert the inverse cup [K] into the circular hole of Z1 and Z2.

2. Insert the square washer [H] into the square bulge of Z2, and fasten the screw [E] into the column.

Note: Only tighten the screws halfway.

3. Before fastening the screw [D], add the spring washer [G] and the flat washer [F] into the screw [D]. Then fasten the screw [D] and tighten.

4. Put the big cap [I] and small cap [M] into the appropriate round holes separately in the arm rest [B].

Note: The small cap [M] differs for left and right. See drawing for assembly.

5. Tighten the 4 screws that connect the backrest [A] and mechanism [C].

6. Ensure that all screws are fully tightened before using the chair.

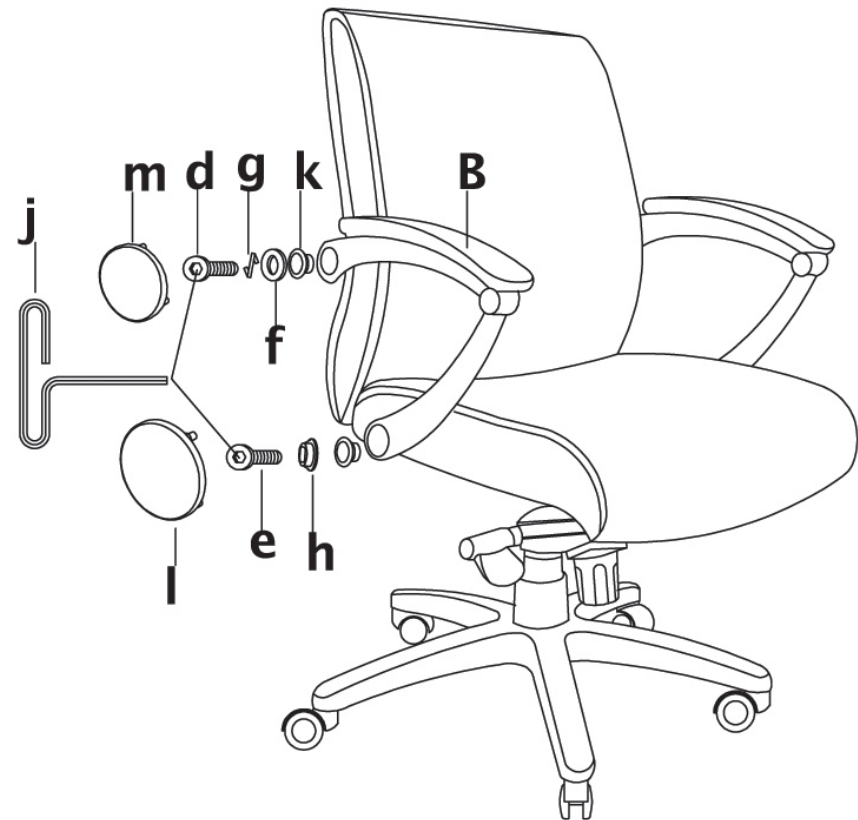
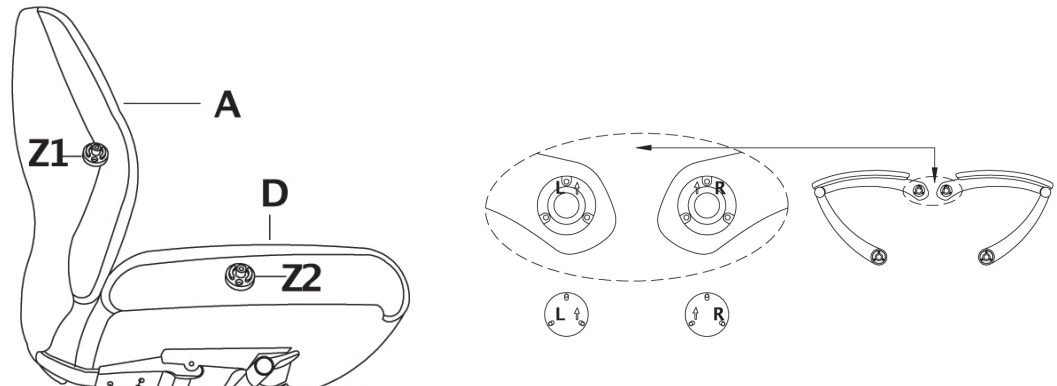

PRODUCT DIMENSIONS

