

USER GUIDE

SIDE VIEW

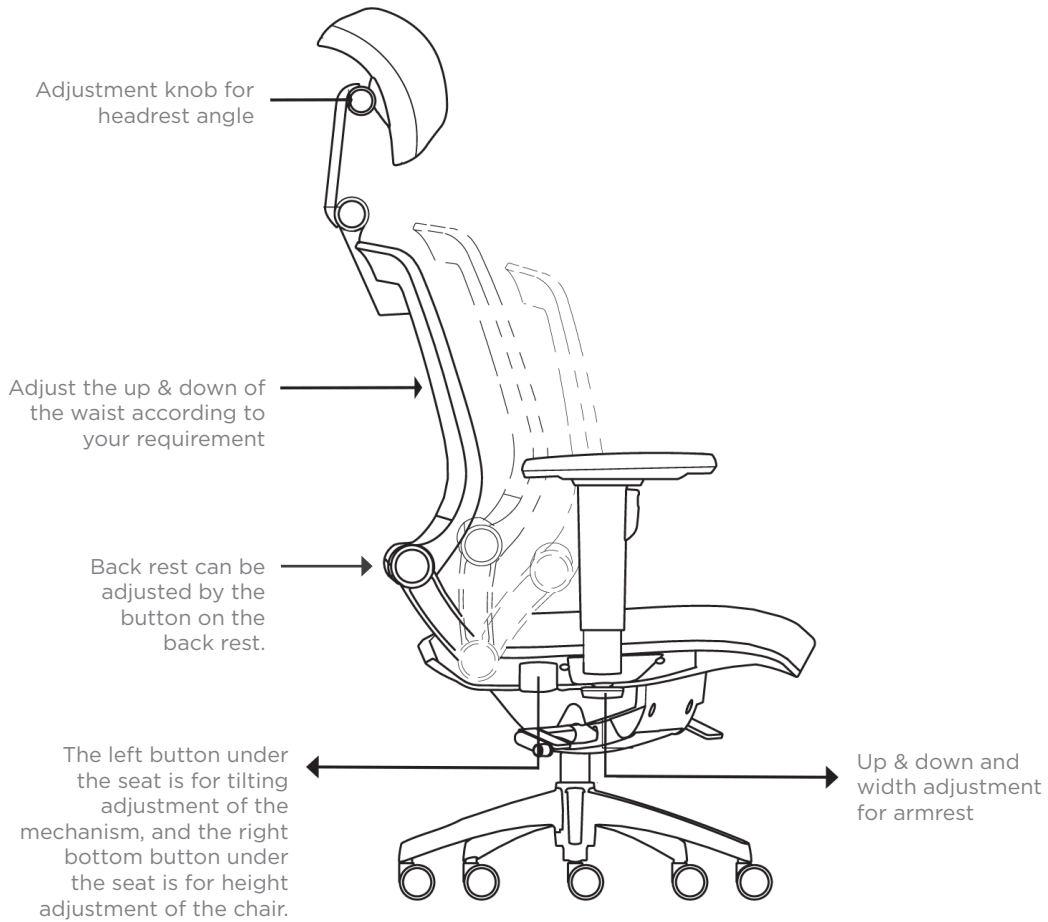

RATCHET-BACK











Two buttons easily release the back from its inward position

ASSEMBLY GUIDE



NOTE: Carefully check all parts according to the instructions before assembling. Please assemble carefully to avoid scratching surfaces, especially powder-coated surfaces.

Parts & Hardware

Item	Parts	Qty.
A	 Back Rest, overall seating	1
B	 Armrest L/R	1 ea
C	 Gas Lift	1
D	 Base	1
E	 Caster	5
F	 Knob for Width Adjustment	2
G	 Headrest	1
H	 Screw 3/16" x 12mm (hex socked M4)	2
J	 Hex Wrench (M4)	1



ASSEMBLY GUIDE

1. Assemble the Base & Casters

Insert the gavellock of the casters [E] into the hole at the rear of the base [D].

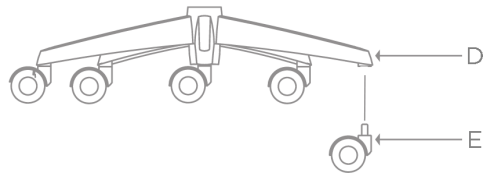

2. Assemble the Gas Lift & Gas Cylinder

Insert the bottom of the gas cylinder [C] into the tapered hole of the base [D].

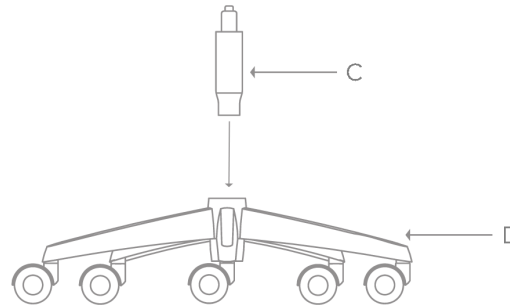

3. Assemble the Headrest & Screw

Put headrest [G] into the backrest and seat set. Tighten the screw [H] with the hex socket wrench [J].

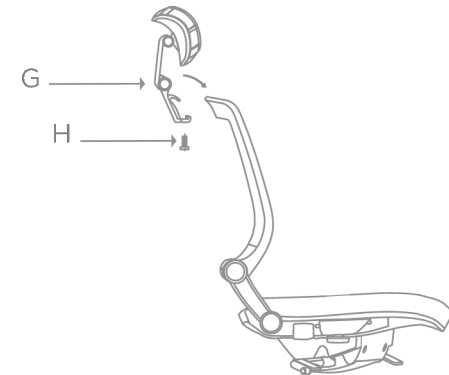

4. Assemble the Back, Seat & Gas Cylinder

Insert the whole part which is assembled with back and seat [A] into the smaller end of the gas cylinder [C].

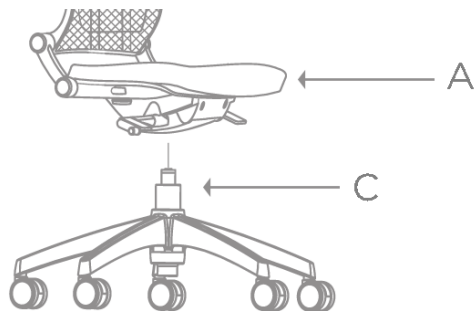

5. Assemble the Armrests & Knob

Insert the left and right armrests [B] into the seat part and lock the width adjustment knob [F].

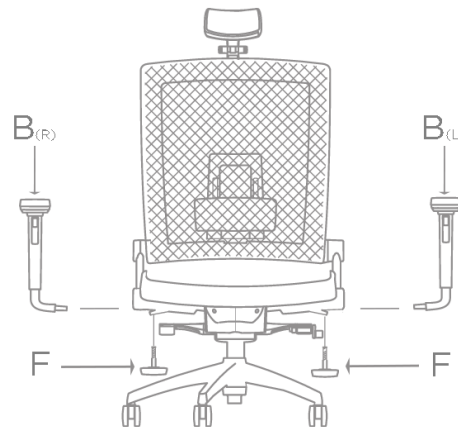

6. Assembly Complete



PRODUCT DIMENSIONS

